



Enriching Lives

**ILLUSTRATED SPARE PART LIST
FOR**

**4R1040TA ENGINE
S/F POWER GENERATION
A/C – INTERNACO (EXPORT)**

**APPLICATION CODE NO.
4H.2549**

KIRLOSKAR OIL ENGINES LIMITED

Regd. Office: Laxmanrao Kirloskar Road, Khadki, Pune - 411 003, INDIA.
Tel.: +91 (20) 2581 0341, 2581 5341. Fax: +91 (20) 2581 3208, 2581 0209.
email: global@koel.co.in Website: www.kirloskar.com

AUGUST – 2006

PUBLICATION NO. 4H.1119.25.0.00

GROUP INDEX
APPLICATION CODE 4H.2549

SR.NO.	GROUP NO.	DESCRIPTION	QTY.	PAGE NO.
1	4H.1208	AIR CLEANER & MOUNTING FOR CCV VALVE (4TA)	1	4
2	4H.227	AIR CLEANER MOUNTING (TA)	1	5
3	4H.223...EXP	AIR INLETMANIFOLD	1	6
4	04.367.1	ALTERNATOR (STAGE 1) MICO, 12V55A	1	7
5	4H.198	ALTERNATOR MOUNTING AND BELT GUARD (TURBO) WITH 68PCD PULLEY SINGLE GROOVE	1	8, 9
6	4H.161.1	BREATHER PIPE (TURBO ENGINE STAGE 1)	1	10
7	4H.224	CAC IN AND OUT PIPE CONNECTION	1	11, 12
8	4H.003	CAMSHAFT	1	13
9	4H.1206	CCV VALVE ARRANGEMENT	1	14, 15
10	4H.266...EXP	COVER FOR FUEL PUMP GEAR (PG)	1	16
11	2H.034	CRANK PULLEY (SPA, SINGLE GR) PG	1	17
12	4H.181	CRANKSHAFT (66 DIA PIN)	1	18
13	4H.063...EXP	CYLINDER HEAD (EXPORT)	1	19 TO 21
14	2H.008	CYLINDER LINER. (105 DIA)	4	22
15	2H.013...EXP	DELIVERY BODY	1	23
16	04.445	DIPSTICK (PRESSED SUMP)	1	24
17	4H.228	ENGINE MNTG.FOOT (225 HT.)	1	25
18	2H.124	ENGINE MOUNTING FOOT (FOR PACKING PURPOSE)	1	26
19	4H.1155	EXHAUST DIFFUSER FOR 4R1040T ENGINE (INTERNACO)	1	27
20	4H.220	EXHAUST MANIFOLD (TA)	1	28
21	49.446	EXHAUST SILENCER WITH FLANGE (RB66TA)	1	29
22	4H.655	EXPANSION BELLOW (2.5" WITH TRANGULAR FLANGE 92 PCD)	1	30
23	4H.038	FLYWHEEL HOUSING (SAE3-144.5)	1	31
24	04.039	FLYWHEEL (C-110 PTO & SP-111 PTO)	1	32
25	4H.179...EXP	FRONT COVER FOR PG APPLICATION	1	33
26	4H.657	FUEL FILTER MOUNTING FOR SPIN ON FILTER (SHANTI)	1	34, 35
27	4H.240...EXP	FUEL PUMP 4RTA (NON ASBESTOS JOINT)	1	36, 37
28	2H.011	FUEL PUMP GEAR.	1	38
29	4H.1074...EXP	GEAR CASING WITH DEFLECTOR	1	39
30	4H.050	HIGH PRESSURE PIPE (700 MM)	1	40
31	4H.154	INJECTOR & MTG. (TURBOCHARGED ENGINE)	4	41
32	4H.237	INTERMEDIATE GEAR AND SUPPORT (FOR ENGINE W/O AUTO TIMER)	1	42
33	4H.516	LEAK OFF PIPE (4R 1040 TA ENGINE SHANTI PROJECT)	1	43
34	4H.170	LIFTING HOOK (TURBO ENGINE)	1	44
35	4H.144...EXP	LUB OIL COOLER AND SPIN ON FILTER [USA]	1	45, 46
36	6H.004	LUB OIL PUMP	1	47, 48

SR.NO.	GROUP NO.	DESCRIPTION	QTY.	PAGE NO.
37	4H.1209	LUB OIL SUMP (FOR CCV VALVE)	1	49
38	2H.092.1	LUBE OIL PR GAUGE SENDOR	1	50
39	2H.301	MICO STARTER 12VDC 2.7KW SUITABLE FOR 30*C	1	51
40	4H.156...EXP	MONOBLOCK CRANKCASE (4RT - EXPORT)	1	52 TO 55
41	4H.027...EXP	OIL FILLING BODY	1	56, 57
42	2H.039...EXP	OIL SEAL HOUSING (PG)	1	58
43	4H.222...EXP	OIL SUPPLY AND DRAIN ARRANGEMENT	1	59, 60
44	4H.180	PISTON AND CON ROD ASSEMBLY (TURBO, P.G. --40 DIA PIN)	4	61, 62
45	2H.007	PUSHROD & TAPPETS	4	63
46	4H.762.1	RADIATOR 4RTA CANOPY GENSET W/O STONE GUARD (WITH 21 " FAN)	1	64 TO 66
47	6H.330	RADIATOR FAN (21" METTALIC PUSHER)	1	67
48	4H.083.1	RADIATOR FAN MTG. (STAGE 1,PG)	1	68
49	4H.160...EXP	ROCKER COVER (EXPORT - USA)	1	69
50	3H.132	SPIN ON FUEL FILTER (MICO NO F002 H20 116)	1	70
51	3H.135.1	STOP SOLENOID ASSEMBLY 12V D.C. FOR MICO PUMP ENERGIES TO RUN WITHOUT TIMER	1	71
52	4H.231	SUCTION TUBE (TURBOCHARGED ENGINE)	1	72
53	4H.096...EXP	THERMOSTAT AND HOUSING ASSEMBLY (USA)	1	73, 74
54	4H.277	TURBOCHARGER (K24 --- 5.11) FOR 4R1040TA ENGINE	1	75
55	4H.069	V BELT (XPA 1250)	1	76
56	4H.008	VALVE ROCKER ASSEMBLY.	1	77, 78
57	4H.226	WATER INLET AND OUTLET CONNECTION FOR RADIATOR	1	79
58	4H.052...EXP	WATER PUMP	1	80, 81
59	4H.005	WATER PUMP PULLEY (120 PCD, 1,SPA)	1	82
60	46.260	WATER TEMP.SW. (95 DEG. +- 3 DEG)	1	83
61	4H.842.76	SET OF JOINTS	1	84, 85
62	4H.842.77	SET OF WASHERS	1	86, 87
63	4H.619.69	SET OF 'O' RINGS	1	87
64	4H.842.78	SET OF HOSES	1	88

**TITLE: -AIR CLEANER & MOUNTING
FOR CCV VALVE (4TA)**

GROUP: - 4H.1208

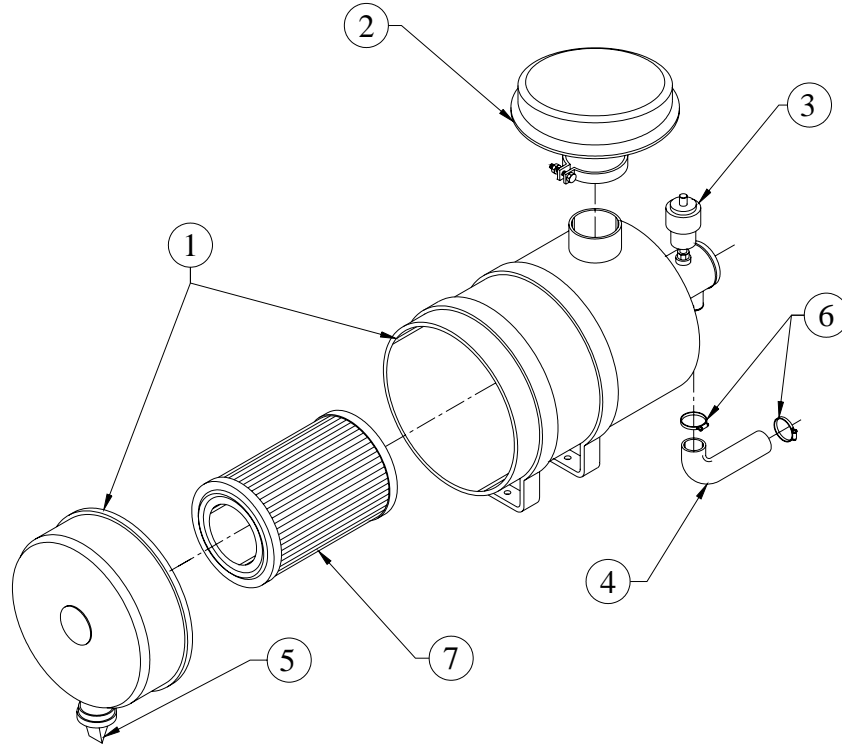

SR.NO.	PART NO.	DESCRIPTION	QTY.	REMARKS
1	4H.1208.10.0.00	AIR CLEANER ASSEMBLY (FOR CCV VALVE)	1	
2	F6.504.35.0.00	HOOD FOR 11.5" JJF FILTER	1	
3	47.113.15.0.00	RESTRICTION INDICATOR - 20"W.G.	1	
4	4H.1208.01.0.00	OUTLET PIPE FOR CCV VALVE (4RTA)	1	
5	06.086.04.0.00	VACUATOR VALVE	1	
6	50.519.07.000.	WORM DRIVE HOSE CLIP (35 MM)	2	

TITLE :- AIR CLEANER MOUNTING(TA)

GROUP :- 4H.227

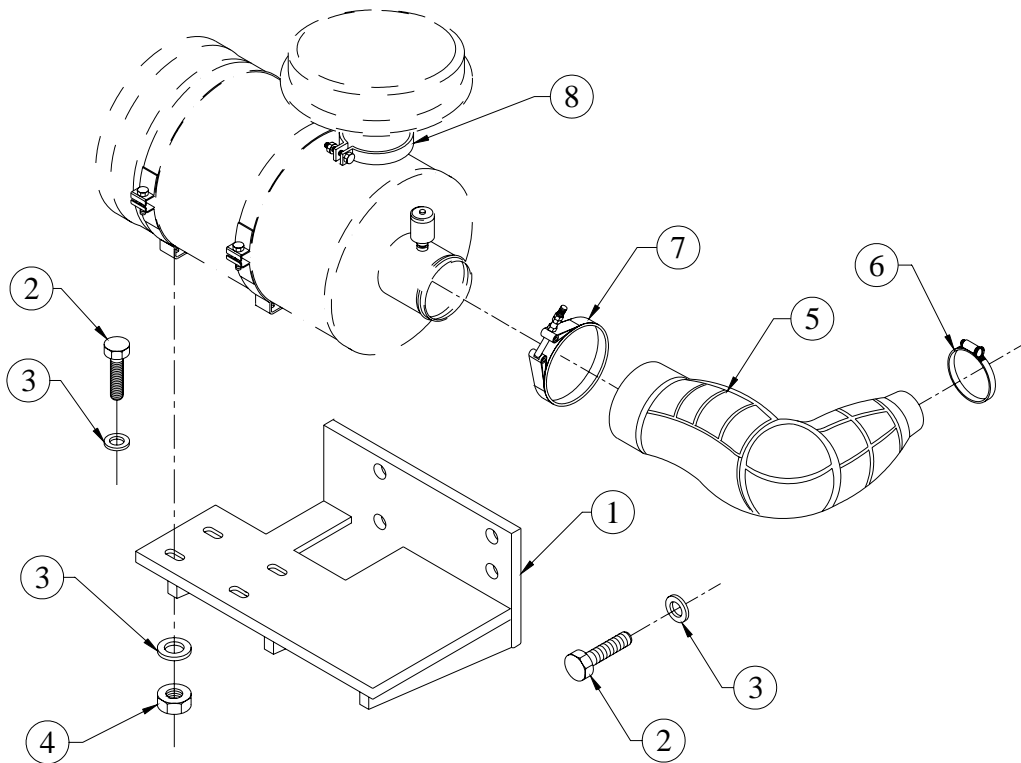

SR.NO.	PART NO.	DESCRIPTION	QTY.	REMARKS
1	4H.227.01.0.00	AIR CLEANER MNTG BRACKET	1	
2	50.003.10.025	SET SCREW - M10X1.5X25 - 8.8	8	
3	50.506.10.000	PLAIN MACHINED WASHER – M10	12	
4	50.006.10.000	NUT - M10X1.5 - GR.8	4	
5	4H.227.02.0.00	HOSE FOR AIR CLEANER (TA ENGINE)	1	
6	48.305.07.0.00	JUPITER WORM DRIVE CLAMP, TYPE 603,80mm DIA (S/F 80mm HOSE O.D.)	1	
7	06.376.04.0.00	JUPITOR HOSECLAMP, SS, TBOLT&NY NUT 115MMD	1	
8	50.519.16.000	WORM DRIVE HOSE CLIP (115 MM)	1	

TITLE: -AIR INLET MANIFOLD

GROUP: -4H.223...EXP

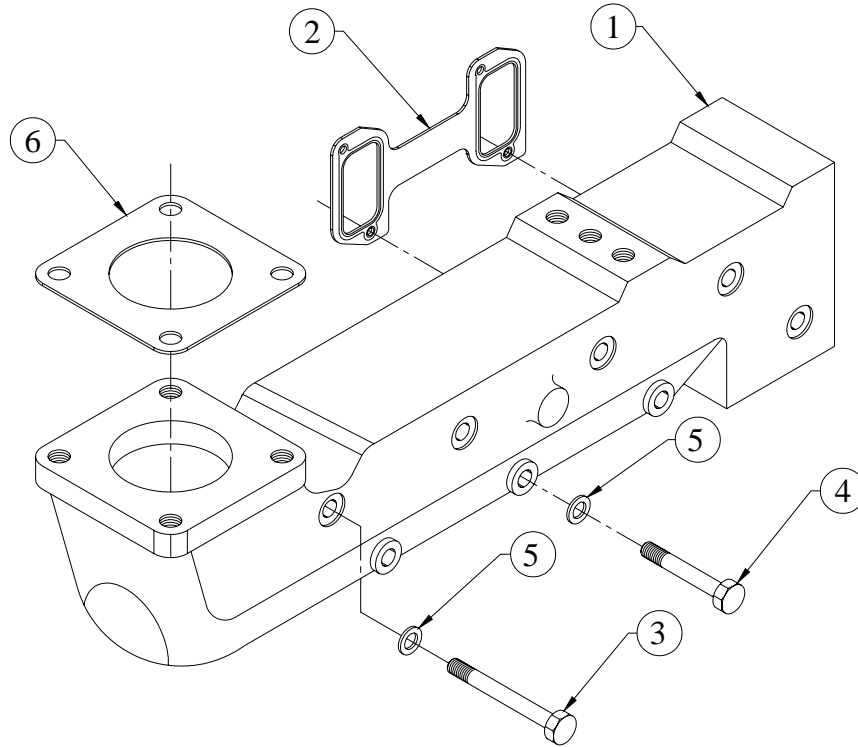

SR.NO.	PART NO.	DESCRIPTION	QTY.	REMARKS
1	4H.223.01.0.00	AIR INLET MANIFOLD (TA)	1	
2	4H.223.11.0.00	JOINT FOR AIR INLET PIPE	2	
3	50.002.08.115	SET BOLT - M8X1.25X115 - 8.8	5	
4	50.002.08.065	SET BOLT - M8X1.25X65 - 8.8	3	
5	50.506.08.000	PLAIN MACHINED WASHER - M8	8	
6	4H.030.11.0.00	JOINT FOR AIR INLET MANIFOLD	1	

TITLE:- ALTERNATOR (STAGE 1)

GROUP:- 04.367.1

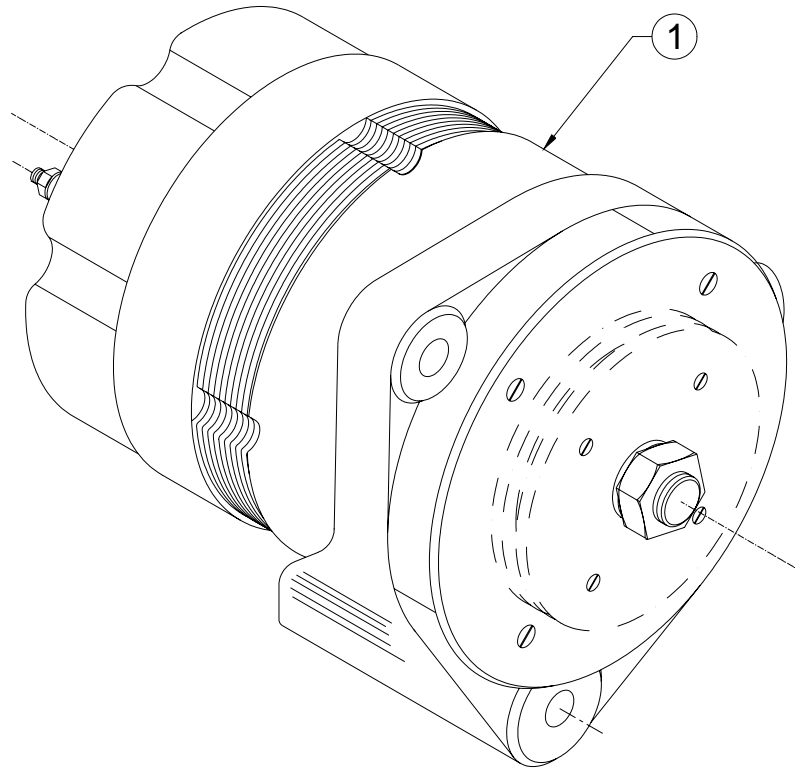

SR.NO.	PART NO.	DESCRIPTION	QTY.	REMARKS
1	04.367.01.0.00	ALT. (MICO, 12V55A) 9 120 030 387	1	

TITLE :- ALTERNATOR MOUNTING AND BLT GAURD (TURBO)

GROUP :- 4H.198

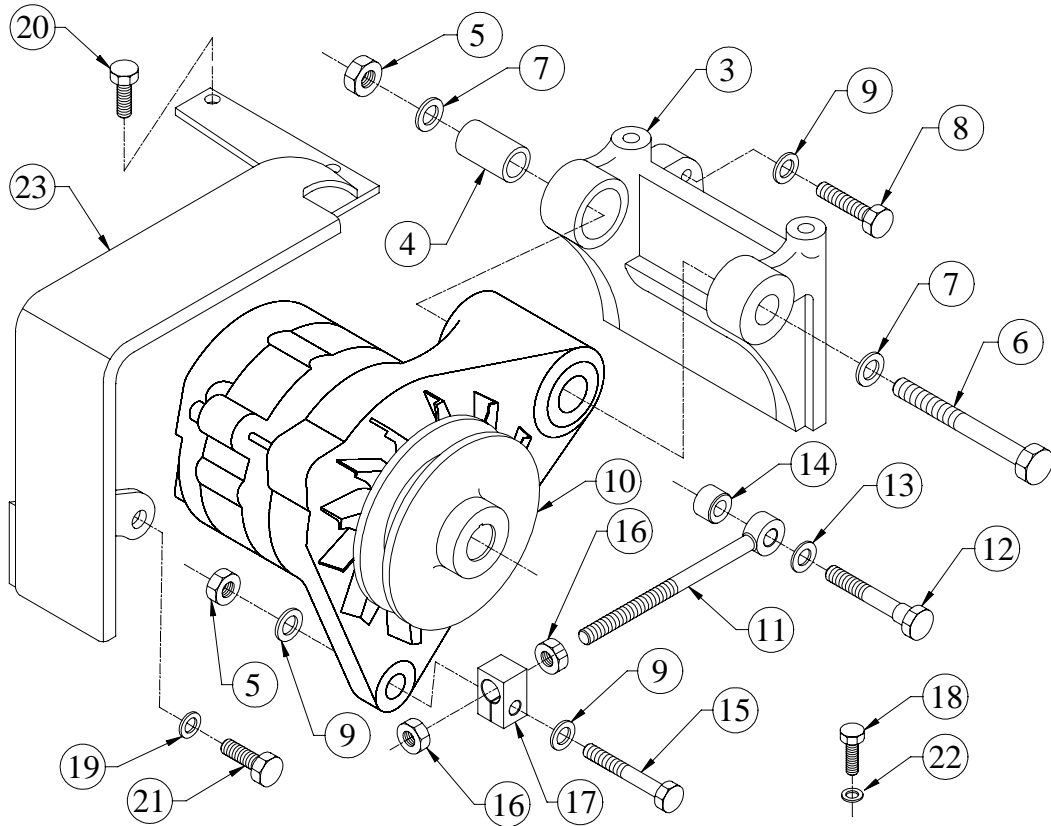

SR.NO.	PART NO.	DESCRIPTION	QTY.	REMARKS
*1	4H.198.10.0.00	ALTERNATOR MOUNTING KIT	1	CONSISTING OF SR. NO.- 2 8 TO 19
*2	4H.044.20.0.00	MOUNTING SUBASLY. FOR ALTERNATOR	1	CONSISTING OF SR. NO.- 3 TO 7
3	48.175.07.0.00	BKT.FOR ALT	1	
4	48.067.04.0.00	BUSH FOR ALTERNATOR (IN BRACKET)	1	
5	50.006.10.000.	NUT - M10X1.5 - GR.8	1	
6	48.067.03.7.00	DOWEL BOLT FOR ALTERNATOR	1	
7	50.506.10.000.	PLAIN MACHINED WASHER - M10	2	
8	50.003.10.040.	SET SCREW - M10X1.5X40 - 8.8	2	
9	50.506.10.000.	PLAIN MACHINED WASHER - M10	6	
10	3H.041.02.0.00	PULLEY FOR ALTERNATOR (SPA 68 PCD)	1	
11	4H.329.24.0.00	EYE BOLT	1	
12	4H.198.02.0.00	LOCATING BOLT (FOR EYE BOLT)	1	
13	50.506.12.000.	PLAIN MACHINED WASHER - M12	1	
14	4H.198.03.0.00	SPACER (FOR EYE BOLT)	1	

TITLE :- ALTERNATOR MOUNTING AND BLT GAURD (TURBO)

GROUP :- 4H.198

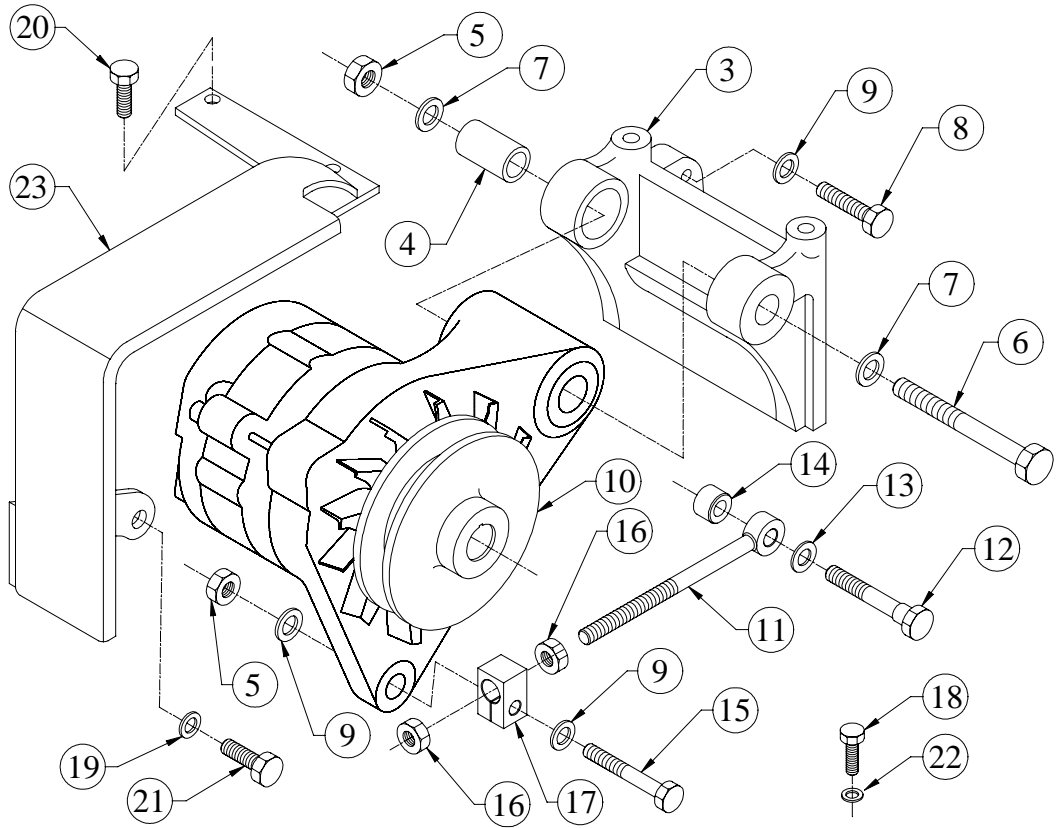

SR.NO.	PART NO.	DESCRIPTION	QTY.	REMARKS
15	50.002.10.055.	SET BOLT - M10X1.5X55 - 8.8	1	
16	50.006.10.000.	NUT - M10X1.5 - GR.8	2	
17	4H.329.26.0.00	SWIVEL PIECE	1	
18	50.003.08.018.	SET SCREW - M8X1.25X18 - 8.8	1	
19	50.506.08.000.	PLAIN MACHINED WASHER - M8	1	
20	50.003.06.012.	SET SCREW - M6X1X12 - 8.8	2	
21	50.003.08.020.	SET SCREW - M8X1.25X20 - 8.8	1	
22	50.506.08.000.	PLAIN MACHINED WASHER - M8	3	
23	4H.198.04.0.00	BELT GUARD	1	

**TITLE :- BREATHER PIPE
(TURBO ENGINE STAGE 1)**

GROUP :- 4H.161.1

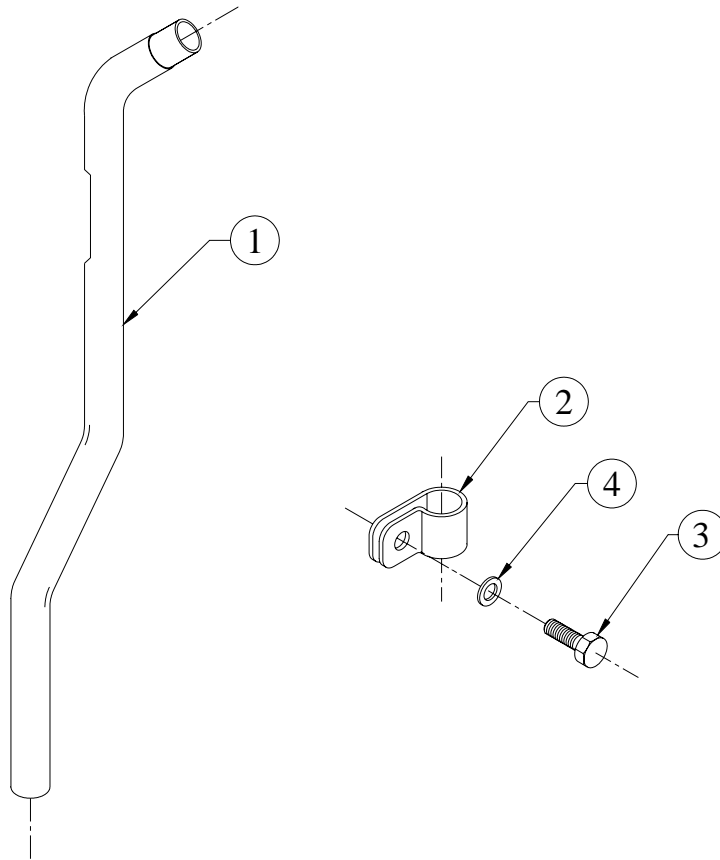

SR.NO.	PART NO.	DESCRIPTION	QTY.	REMARKS
1	4H.161.05.0.00	BREATHER PIPE	1	
2	4H.161.06.0.00	CLIP FOR BREATHER PIPE	1	
3	50.003.08.020.	SET SCREW - M8X1.25X20 - 8.8	1	
4	50.506.08.000.	PLAIN MACHINED WASHER - M8	1	

TITLE: - CAC IN AND CAC OUT PIPE CONN.

GROUP: - 4H.224

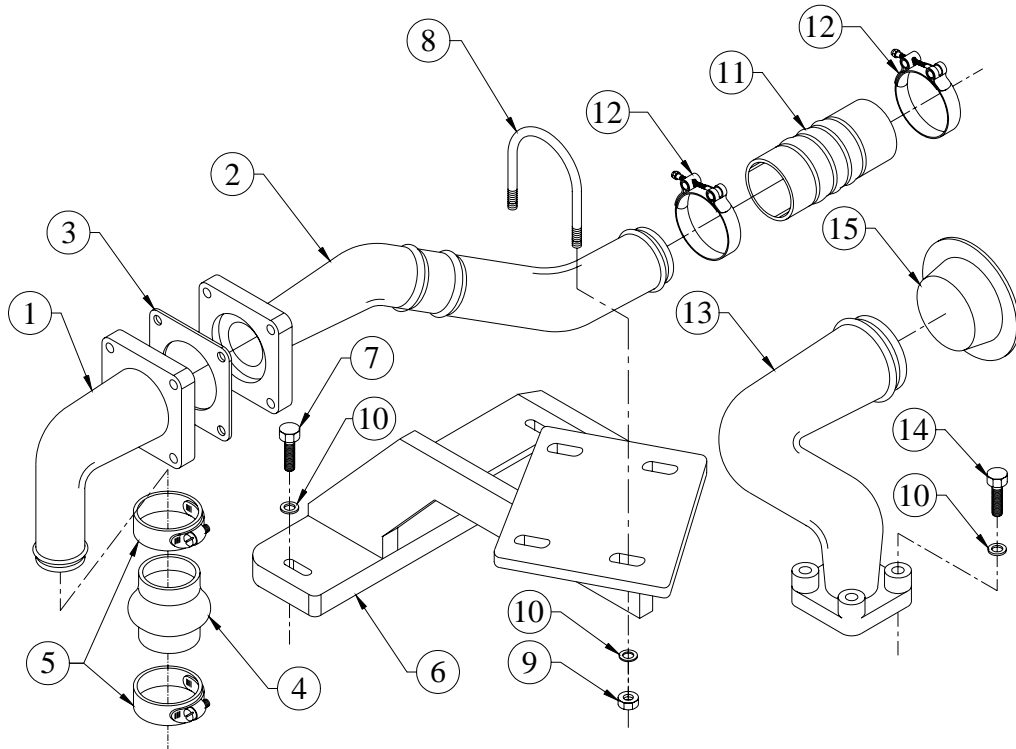

SR.NO.	PART NO.	DESCRIPTION	QTY.	REMARKS
1	4H.224.06.0.00	AIR PIPE (TURBO SIDE)	1	
2	4H.224.07.0.00	AIR PIPE (CAC SIDE)	1	
3	4H.224.08.0.00	JOINT (AIR PIPE)	1	
4	4H.168.03.0.00	RUBBER HOSE (COMPRESSOR OUTLET) K24 TURBO	1	
5	30.650.04.0.00	HOSE CLIP (S.S.60 DIA.)	2	
6	4H.224.02.0.00	BRACKET FOR AIR PIPE	1	
7	50.003.08.020.	SET SCREW - M8X1.25X20 - 8.8	2	
8	4H.224.03.0.00	U CLAMP	2	
9	50.006.08.000.	NUT- M8X1.25 - GR.8	4	
10	50.506.08.000.	PLAIN MACHINED WASHER - M8	10	
11	F6.680.06.0.00	RUBBER HOSE 100 X 100 X 160 LENGTH WITH 4 STEEL RINGS	2	
12	06.376.04.0.00	T BOLT CLAMP KLIPCO TB108 / JUPITOR (108 TO 116 DIA)	4	
13	4H.224.04.0.00	AIR PIPE (CAC TO AIR INLET MANIFOLD)	1	

TITLE: - CAC IN AND CAC OUT PIPE CONN.

GROUP: - 4H.224

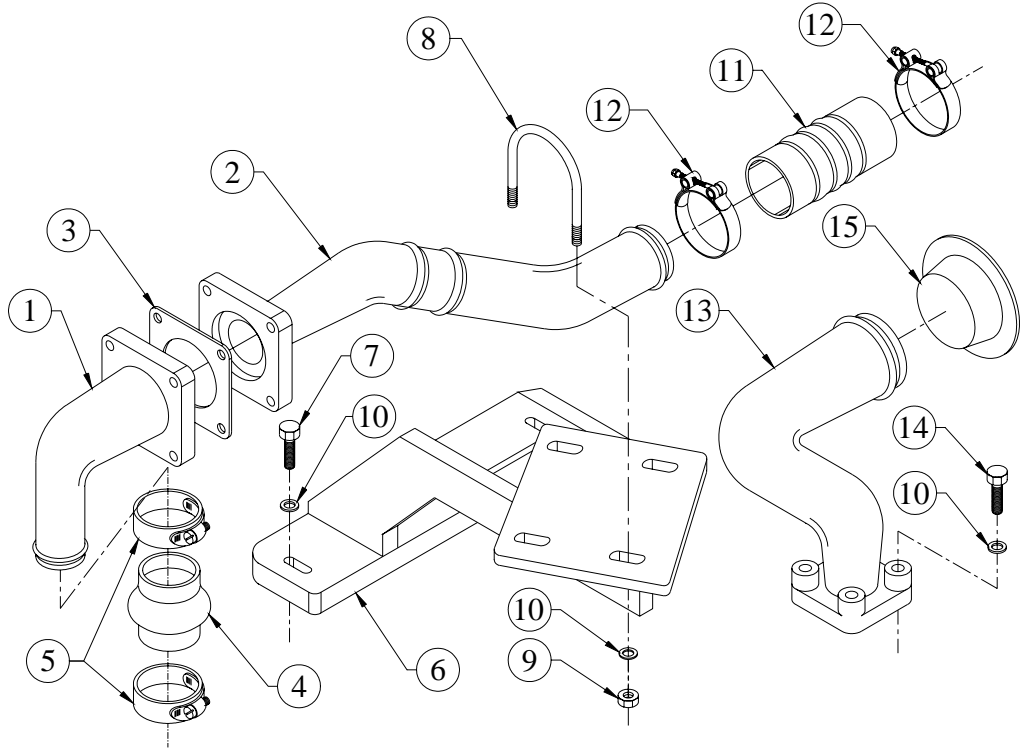

SR.NO.	PART NO.	DESCRIPTION	QTY.	REMARKS
14	50.003.08.040.	SET SCREW - M8X1.25X40 - 8.8	4	
15	4H.224.13.0.00	CAP FOR CAC PIPE	2	

TITLE: - CAMSHAFT

GROUP: - 4H.003

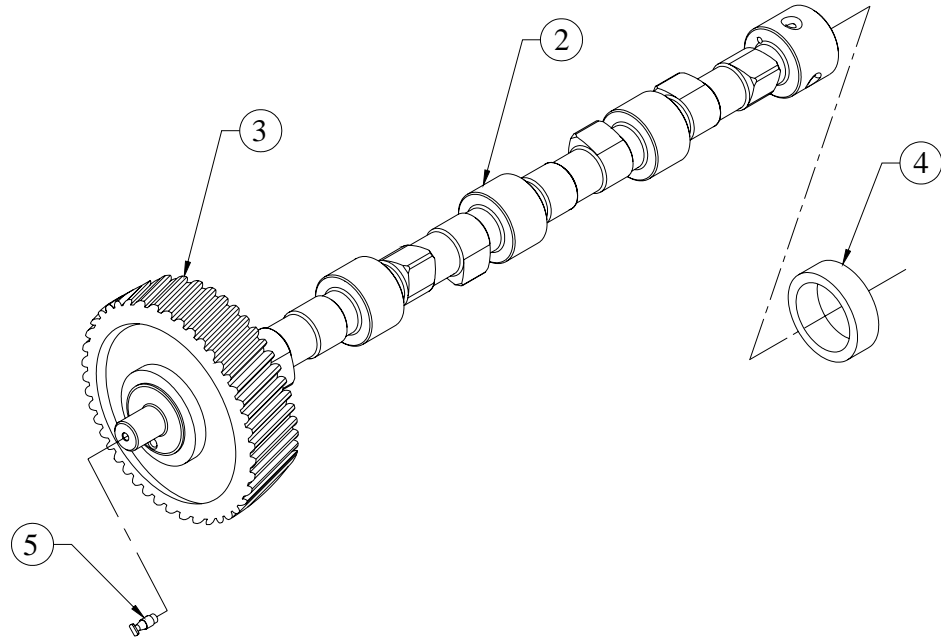

SR.NO.	PART NO.	DESCRIPTION	QTY.	REMARKS
*1	4H.003.20.0.00	CAMSHAFT SUBASSLY	1	CONSISTING OF SR. NO. 2 & 3
2	4H.003.01.0.00	CAM SHAFT. (FINISH)	1	
3	03.006.04.0.00	CAM SHAFT GEAR	1	
4	4H.003.02.0.00	THRUST WASHER FOR CAM SHAFT	1	
5	03.117.02.0.00	PIN	1	

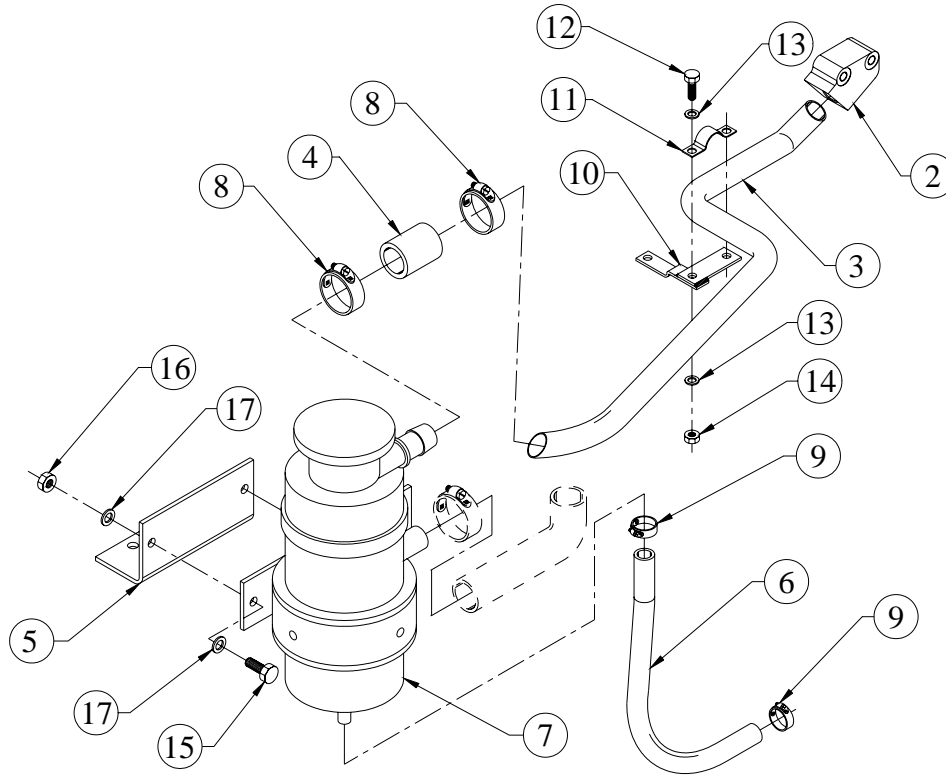
TITLE: -CCV VALVE ARRANGEMENT**GROUP: - 4H.1206**

SR.NO.	PART NO.	DESCRIPTION	QTY.	REMARKS
*1	4H.1206.10.0.PR	SUB ASSEMBLY OF ADAPTOR FOR ROCKER COVER	1	CONSISTING OF SR. NO.- 2 & 3
2	4H.1206.01.0.PR	ADAPTOR (FOR ROCKER COVER)	1	
3	4H.1206.02.0.PR	INLET PIPE (FOR CCV VALVE)	1	
4	02.601.04.0.00	HOSE FOR INLET PIPE	1	
5	4H.1206.03.0.PR	MOUNTING BRACKET (FOR CCV VALVE)	1	
6	4H.1206.04.0.PR	DRAIN PIPE (FOR CCV VALVE)	1	
7	6H.441.12.0.00	CCV VALVE (DONALDSON -- PART NO. SPS040019)	1	
8	50.519.07.000	WORM DRIVE HOSE CLIP (35 MM)	4	
9	50.519.03.000	WORM DRIVE HOSE CLIP (22 MM)	2	
10	4H.1206.05.0.PR	CLAMP BRACKET (FOR INLET PIPE)	1	
11	02.601.08.0.00	CLAMP FOR BREATHER INLET PIPE	1	
12	50.003.08.020	SET SCREW - M8X1.25X20 - 8.8	4	
13	50.506.08.000	PLAIN MACHINED WASHER - M8	4	

TITLE: -CCV VALVE ARRANGEMENT

GROUP: - 4H.1206

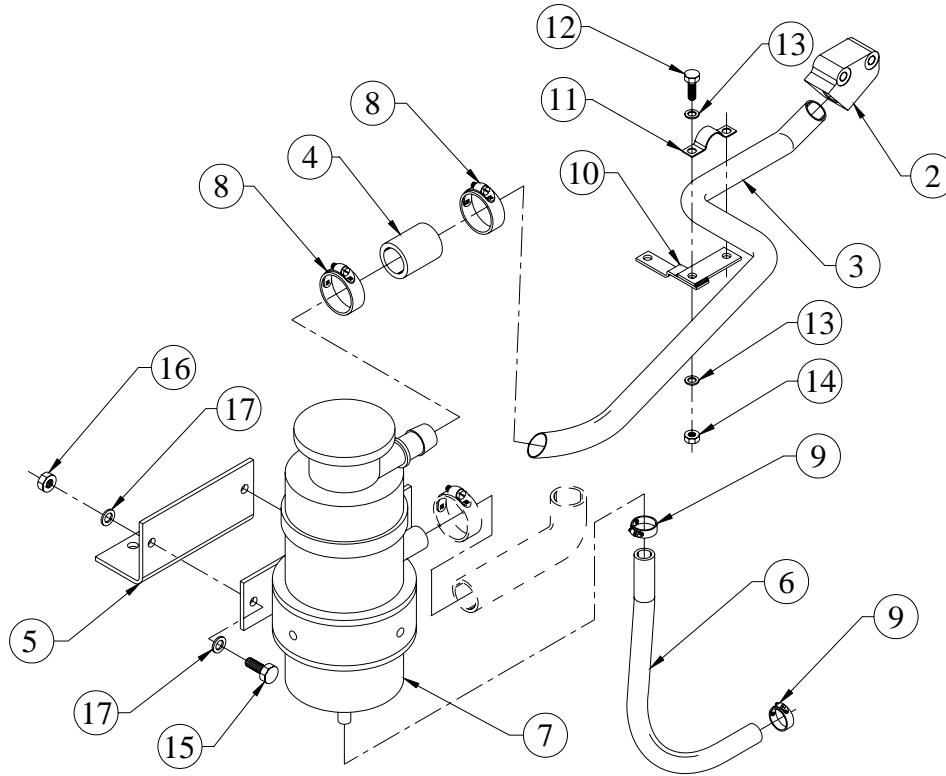

SR.NO.	PART NO.	DESCRIPTION	QTY.	REMARKS
14	50.006.08.000	NUT- M8X1.25 - GR.8	4	
15	50.003.10.020	SET SCREW - M10X1.5X20 - 8.8	5	
16	50.006.10.000	NUT - M10X1.5 - GR.8	2	
17	50.506.10.000	PLAIN MACHINED WASHER - M10	5	

TITLE :- COVER FOR FUEL PUMP GEAR (PG)

GROUP :- 4H.266...EXP

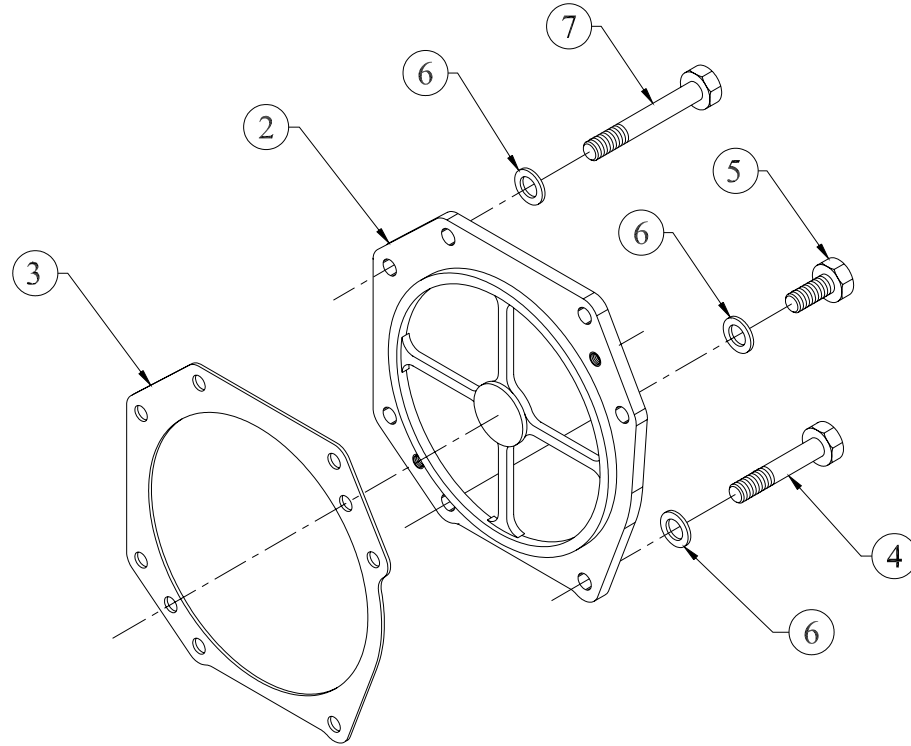

SR.NO.	PART NO.	DESCRIPTION	QTY.	REMARKS
*1	4H.266.10.0.00	COVER FOR FUEL PUMP GEAR WITH JOINT (USA)	1	CONSISTING OF SR NO.- 2 & 3
2	2H.017.03.0.00	COVER FOR FUEL PUMP GEAR	1	
3	2H.017.11.0.00	JOINT FOR FUEL PUMP GEAR	1	
4	50.002.08.045	SET BOLT - M8X1.25X45 - 8.8	3	
5	50.003.08.020	SET SCREW - M8X1.25X20 - 8.8	2	
6	50.506.08.000	PLAIN MACHINED WASHER - M8	7	
7	50.002.08.065	SET BOLT - M8X1.25X65 - 8.8	2	

TITLE :- CRANK PULLEY (SPA SINGLE GROOVE) PG

GROUP :- 2H.034

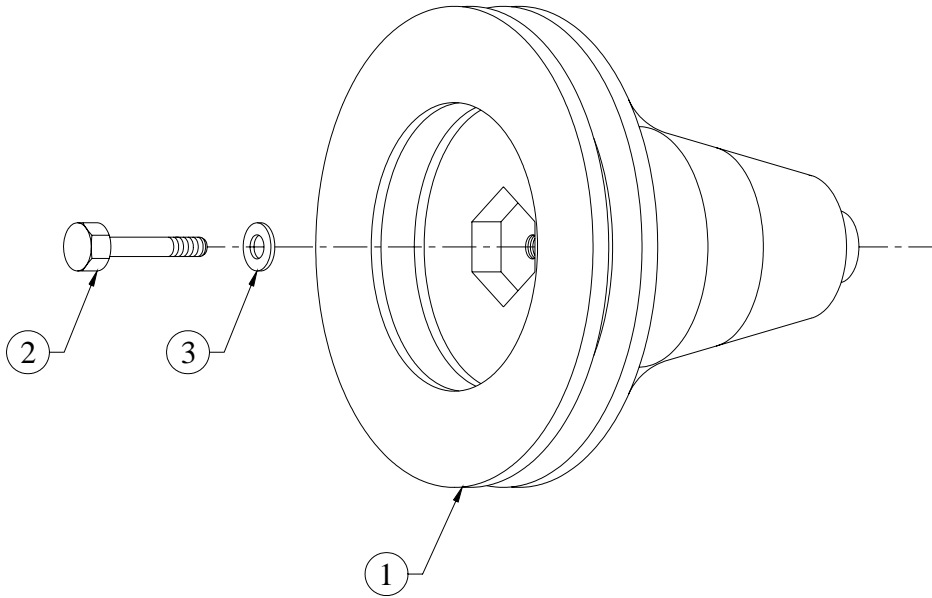

SR.NO.	PART NO.	DESCRIPTION	QTY.	REMARKS
1	2H.034.01.0.00	CRANK PULLEY (SPA SINGLE GROOVE) PG	1	
2	03.016.02.0.00	CRANK PULLY BOLT-UPDATED	1	
3	03.016.03.0.00	WASHER (FOR CRANK PULLY BOLT)-UPDATED	1	

TITLE: -CRANKSHAFT (66 DIA PIN)

GROUP: -4H.181

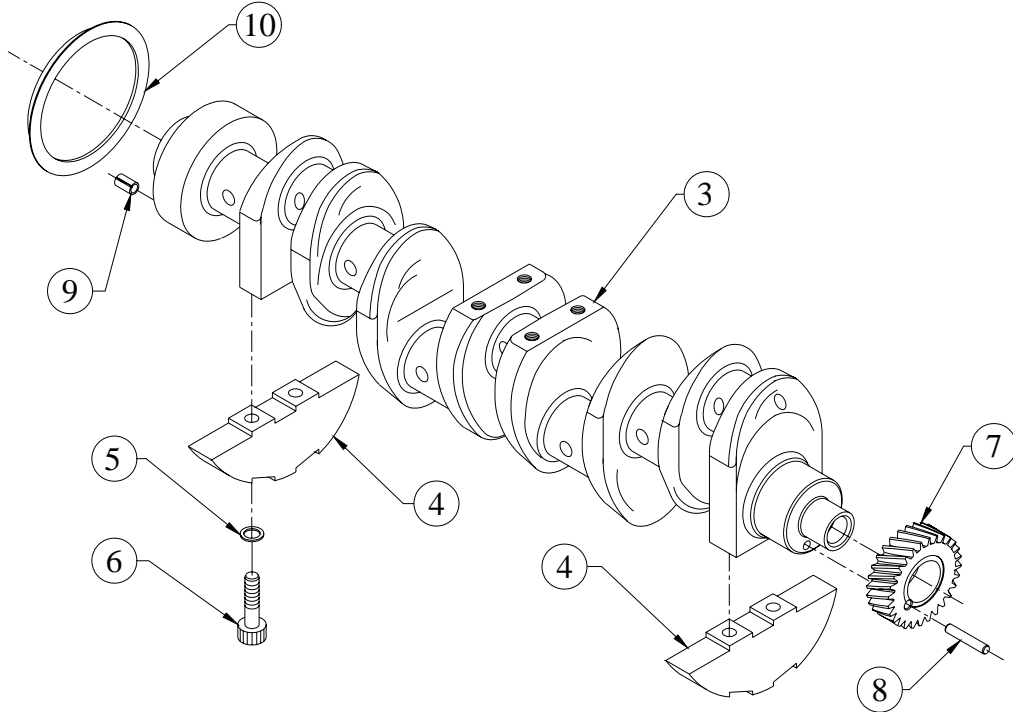

SR.NO.	PART NO.	DESCRIPTION	QTY.	REMARKS
*1	4H.181.10.0.00	CRANKSHAFT ASSLY. WITH GEAR	1	CONSISTING OF SR. NO.- 2 & 7 TO 10
*2	4H.181.20.0.00	CRANK SHAFT ASSEMBLY.	1	CONSISTING OF SR. NO.- 3 TO 6
3	4H.181.02.0.00	CRANKSHAFT (SINGLE OIL HOLE) (F)	1	
4	04.005.11.0.00	BALANCE WT.	4	
5	02.005.04.0.00	WASHER	8	
6	04.005.12.0.00	SOCKET HEAD BOLT - M12X1.75X60 -10.9	8	
7	4H.002.01.0.00	CRANK SHAFT GEAR (FINISH/)	1	
8	50.401.08.060	DOWEL PIN 8X60	1	
9	50.401.08.025	DOWEL PIN 8X25	1	
10	P2.020.09.0.PR	DEFLECTOR FOR FWE OIL SEAL	1	

TITLE: - CYLINDER HEAD (EXPORT)

GROUP: - 4H.063...EXP

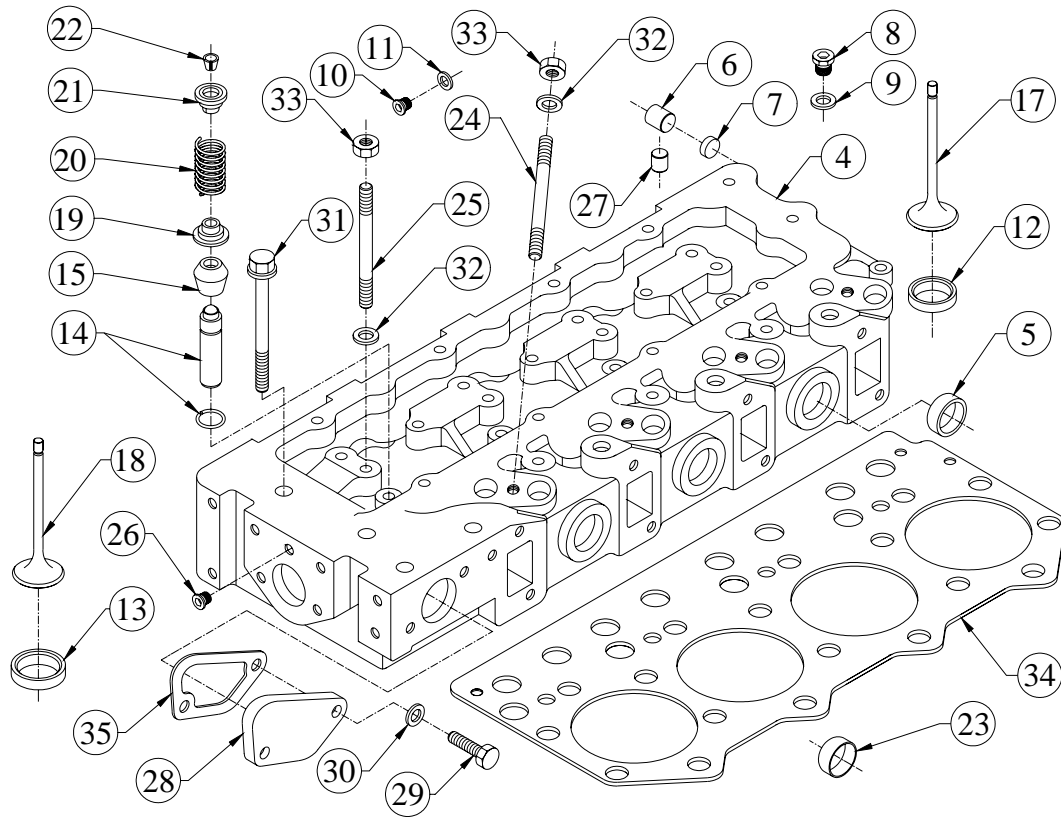

SR.NO.	PART NO.	DESCRIPTION	QTY.	REMARKS
*1	4H.007.30.0.00	CYLINDER HEAD ASSEMBLY COMPLETE	1	CONSISTING OF SR. NO. 2 & 15 TO 27
*2	4H.007.20.0.00	CYL.HEAD WITH VLV.GUIDE & VLV.SEAT INSERT	1	CONSISTING OF SR. NO. 3 & 12 TO 14
*3	4H.007.10.0.00	CYLINDER HEAD ASSEMBLY-COMPLETE.	1	CONSISTING OF SR. NO. 4 TO 11
4	4H.007.01.0.00	CYLINDER HEAD (FINISH)	1	
5	F6.007.35.0.00	SEALING CAP	3	
6	34.003.07.0.00	CRANK SHAFT PLUG – ALUMINIUM	5	
7	34.003.08.0.00	WASHER FOR ALU.PLUG.	5	
8	50.610.16.000.	CORE PLUG-HEXAGONAL SOCKET HEAD (DIN-908)	1	
9	50.508.16.000.	COPPER WASHER (18X22)	1	
10	50.610.24.000.	CORE PLUG	3	

TITLE: - CYLINDER HEAD (EXPORT)

GROUP: - 4H.063...EXP

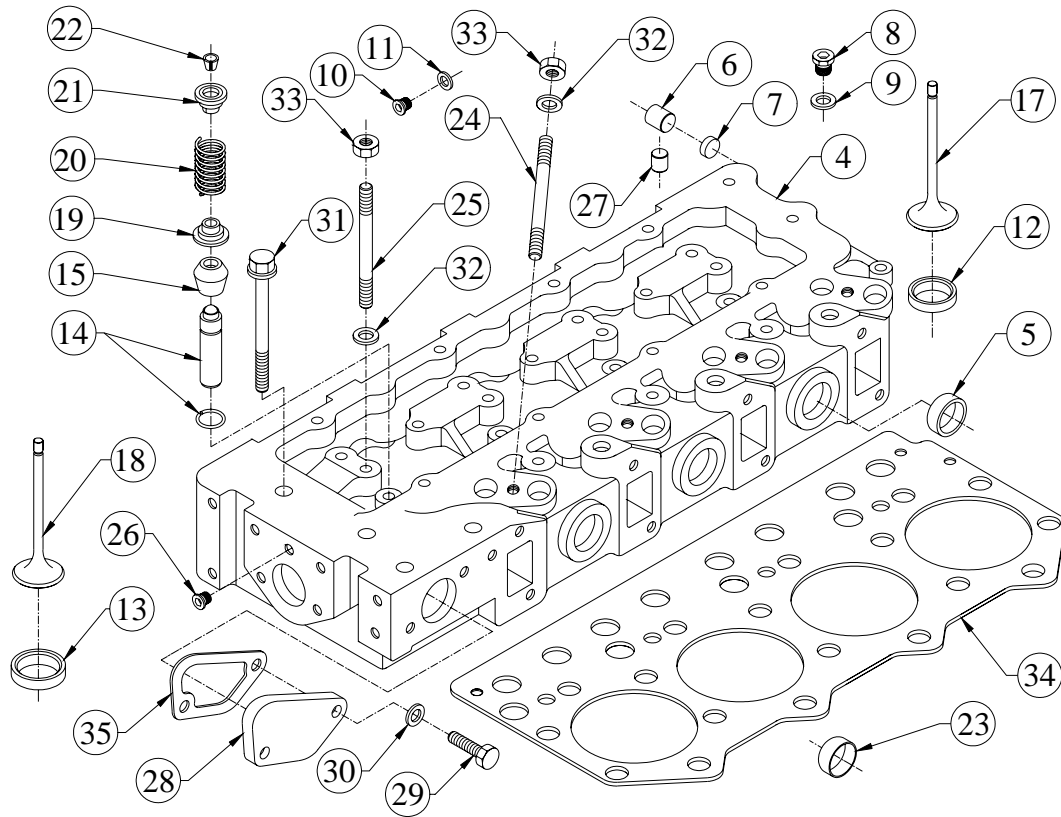

SR.NO.	PART NO.	DESCRIPTION	QTY.	REMARKS
11	50.508.29.000.	COPPER WASHER (26X32)	3	
12	4H.007.03.9.00	VALVE SEAT INSERT (INLET)	4	
13	4H.007.04.9.00	VALVE SEAT INSERT (EXHAUST)	4	
14	4H.007.38.0.00	ASSEMBLY OF SEMIFINISH VALVE GUIDE & SNAP RING	8	
15	06.631.02.0.00	VALVE SEAL	8	
*16	4H.007.40.0.00	INLET & EXHAUST VALVE PAIR	4	CONSIST OF SR. NO. 17 & 18
17	4H.007.05.0.00	INLET VALVE.	4	
18	4H.007.06.0.00	EXHAUST VALVE.	4	
19	34.013.13.0.00	CUP FOR VALVE SPRING.	8	
20	02.022.13.0.00	VALVE SPRING	8	
21	02.022.11.0.00	VALVE CUP	8	
2	02.022.12.0.00	VALVE COLLET	16	
23	F6.001.58.0.00	SEALING CAP. (40 DIN 443)	1	
24	50.010.10.070.	STUD - M10X1.5X70 - 8.8	4	
25	50.010.10.050.	STUD - M10X1.5X50 - 8.8	4	
26	4H.007.26.0.00	CORE PLUG (FOR CYL.HEAD-EJCB)	1	
27	4H.007.08.0.00	BUTTON FOR INJECTOR YOKE.	4	

TITLE: - CYLINDER HEAD (EXPORT)

GROUP: - 4H.063...EXP

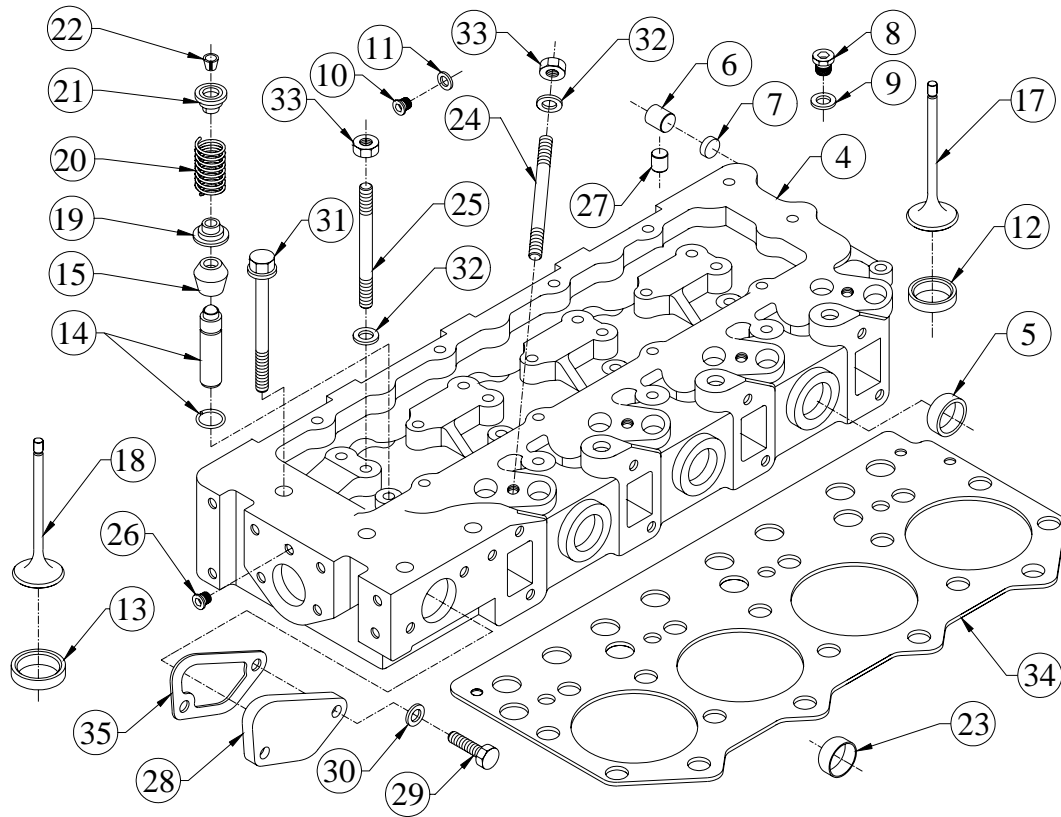

SR.NO.	PART NO.	DESCRIPTION	QTY.	REMARKS
28	4H.063.01.0.00	BLANKING PLATE FOR WATER OUTLET (ON HEAD)	1	
29	50.003.08.020.	SET SCREW - M8X1.25X20 - 8.8	2	
30	50.506.08.000.	PLAIN MACHINED WASHER - M8	2	
31	4H.007.07.0.00	BOLT FOR CYLINDER HEAD.	18	
32	50.506.10.000.	PLAIN MACHINED WASHER - M10	8	
33	50.006.10.000.	NUT - M10X1.5 - GR.8	8	
34	4H.007.24.0.00	GASKET FOR CYL. HEAD (THICKNESS 1.25)	1	
35	4H.022.11.0.00	JOINT FOR WATER OUTLET MANIFOLD	1	

TITLE:- CYLINDER LINER (105 DIA)

GROUP:- 2H.008

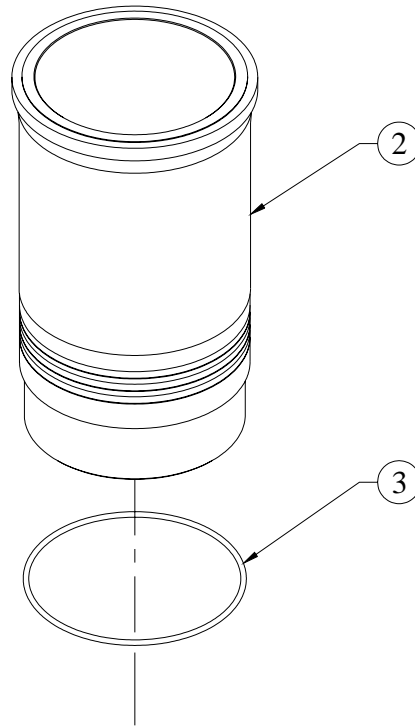

SR.NO.	PART NO.	DESCRIPTION	QTY.	REMARKS
*1	2H.008.10.0.00	CYLINDER WITH 'O' RING	1	CONSISTING OF SR. NO. 2 & 3
2	2H.008.01.0.00	CYLINDER LINER (105mm DIA.) A-GROUP	1	
3	2H.008.07.0.00	O RING (FOR CYL.LINER)	3	

TITLE:- DELIVERY BODY

GROUP:- 2H.013...EXP

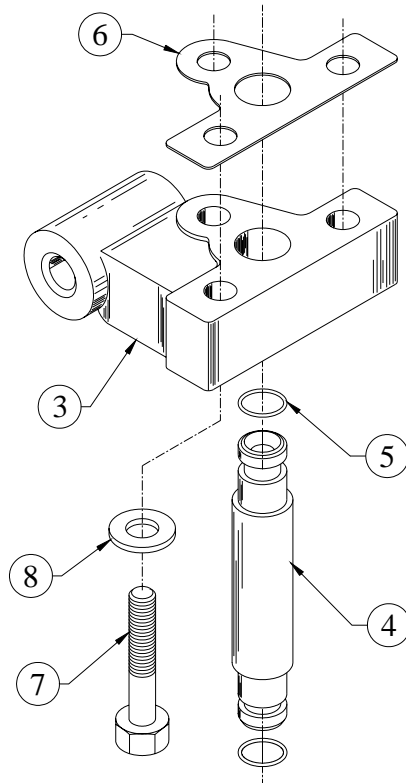

SR.NO.	PART NO.	DESCRIPTION	QTY.	REMARKS
*1	2H.013.20.0.00	DELIVERY BODY AND JOINT (NON ASBESTOS)	1	CONSISTING OF SR. NO. 2 & 6
*2	2H.013.10.0.00	DELIVERY BODY ASSEMBLY	1	CONSISTING OF SR. NO. 3 TO 5
3	2H.013.01.0.00	DELIVERY BODY (FINISH)	1	
4	2H.014.01.0.00	DELIVERY TUBE	1	
5	2H.014.02.0.00	O RING (FOR DELIVERY TUBE)	2	
6	2H.013.11.0.00	JOINT FOR DELIVERY BODY	1	
7	50.002.08.045.	SET BOLT - M8X1.25X45 - 8.8	3	
8	50.506.08.000.	PLAIN MACHINED WASHER - M8	3	

TITLE :- DIPSTICK (PRESSED SUMP)

GROUP :- 04.445

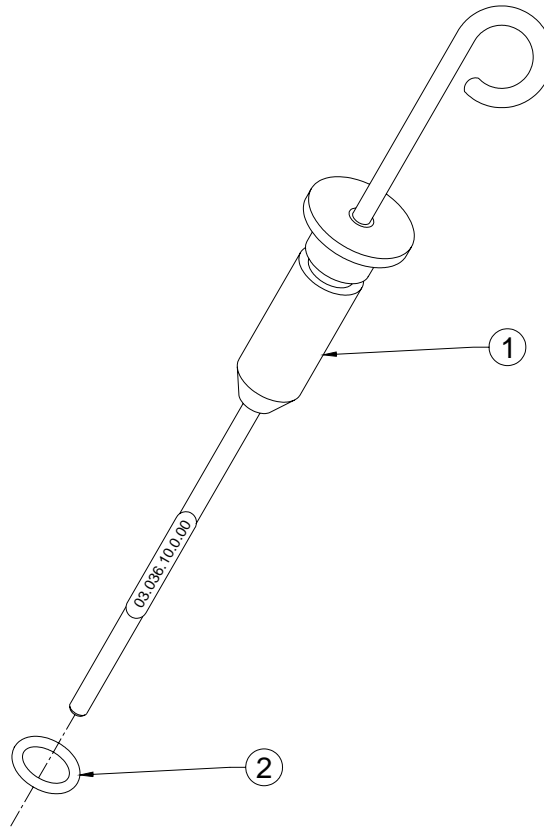

SR.NO.	PART NO.	DESCRIPTION	QTY.	REMARKS
1	04.445.10.0.00	DIPSTICK ASSLY (PRESSED SUMP210-170X25-38	1	
2	03.036.01.0.00	O RING - DIPSTICK (2X5, 21515 OR 21511)	1	

TITLE :- ENGINE MOUNTING FOOT (225 HT.)

GROUP :- 4H.228

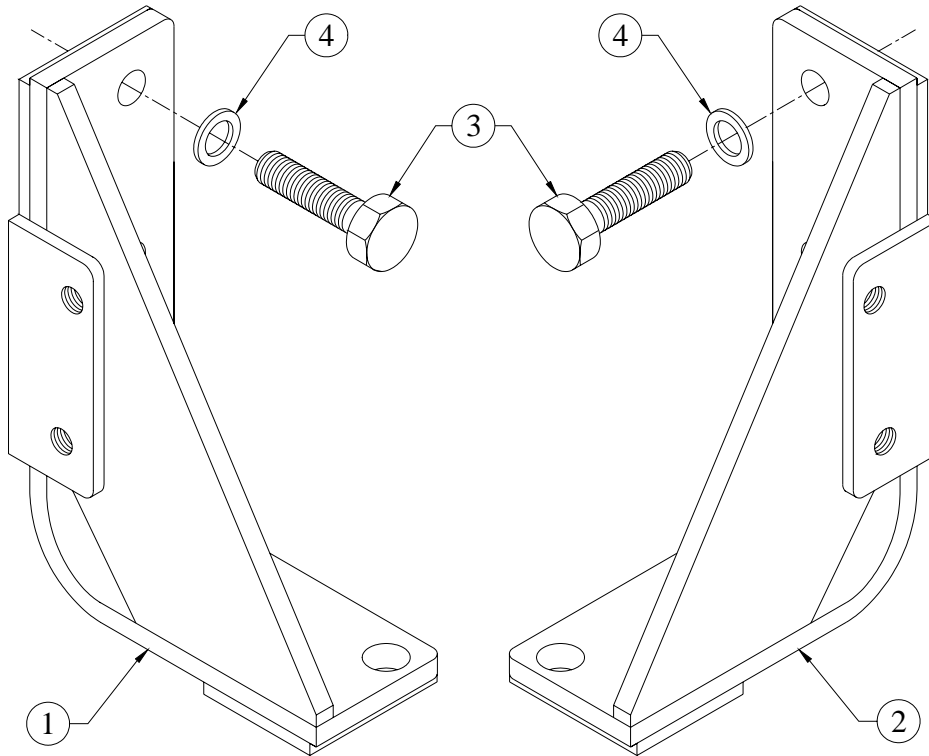

SR.NO.	PART NO.	DESCRIPTION	QTY.	REMARKS
1	4H.228.01.0.00	CRANKCASE FOOT (F P SIDE 225 HT.)	1	
2	4H.228.02.0.00	CRANKCASE FOOT (STARTER SIDE 225 HT.)	1	
3	50.003.12.035	SET SCREW - M12X1.75X35 - 8.8	4	
4	02.005.04.0.00	WASHER	4	

**TITLE: - ENGINE MTG. FOOT
FOR PACKING PURPOSE**

GROUP: - 2H.124

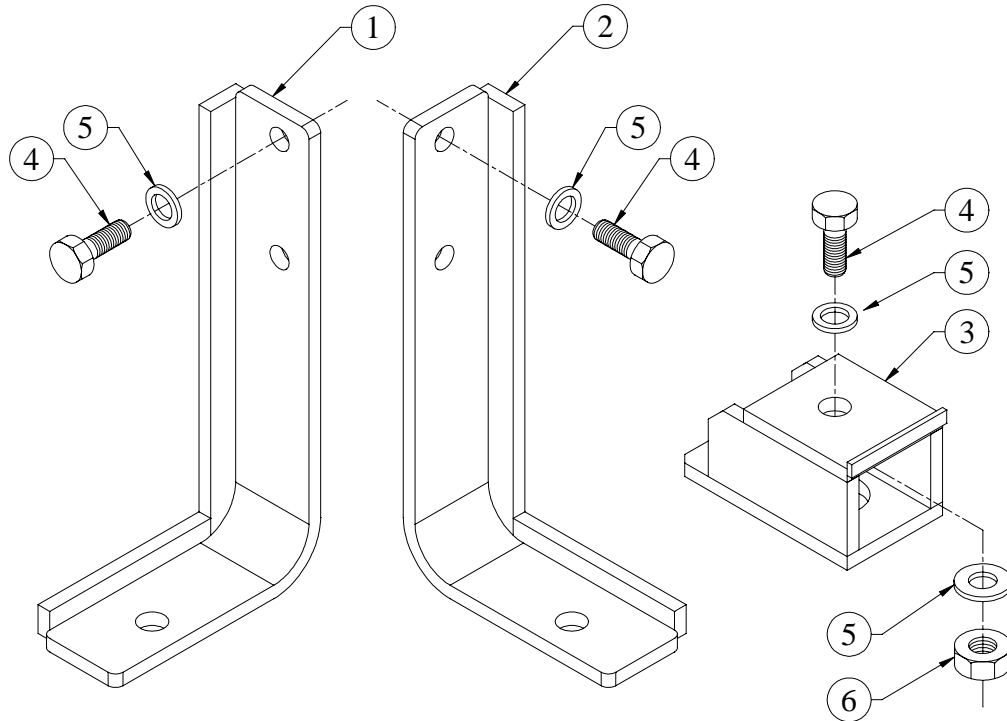

SR.NO.	PART NO.	DESCRIPTION	QTY.	REMARKS
1	2H.124.03.0.00	CRANK CASE FOOT (GEAR END), FUEL PUMP SIDE	1	
2	2H.124.04.0.00	CRANK CASE FOOT (GEAR END), STARTER SIDE	1	
3	2H.124.05.0.00	SUPPORT FOR MOUNTING FOOT	2	
4	50.003.12.030.	SET SCREW - M12X1.75X30 - 8.8	6	
5	50.506.12.000.	PLAIN MACHINED WASHER - M12	8	
6	50.006.12.000.	NUT - M12X1.75 – GR.8	2	

**TITLE:- EXHAUST DIFFUSER FOR 4R1040T
ENGINE (INTERNACO)**

GROUP:- 4H.1155

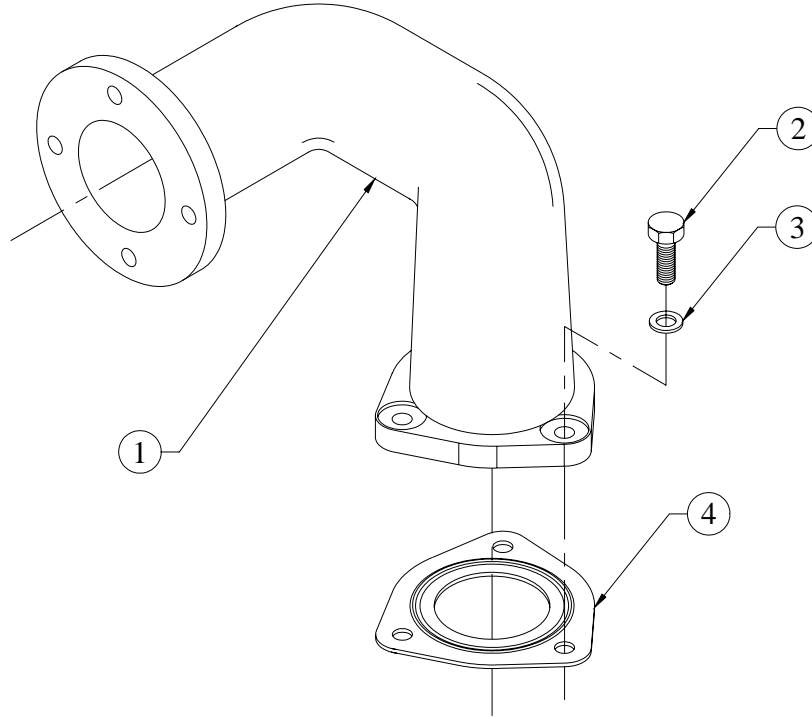

SR.NO.	PART NO.	DESCRIPTION	QTY.	REMARKS
1	4H.1155.01.0.00	EXHAUST DIFFUSER (FOR INTERNACO DOWNWARD)	1	
2	50.003.08.025.	SET SCREW - M8X1.25X25 - 8.8	3	
3	50.506.08.000.	PLAIN MACHINED WASHER - M8	5	
4	4H.522.03.0.00	JOINT FOR EXH. DIFFUSER	1	

TITLE :- EXHAUST MANIFOLD (TA)

GROUP :- 4H.220

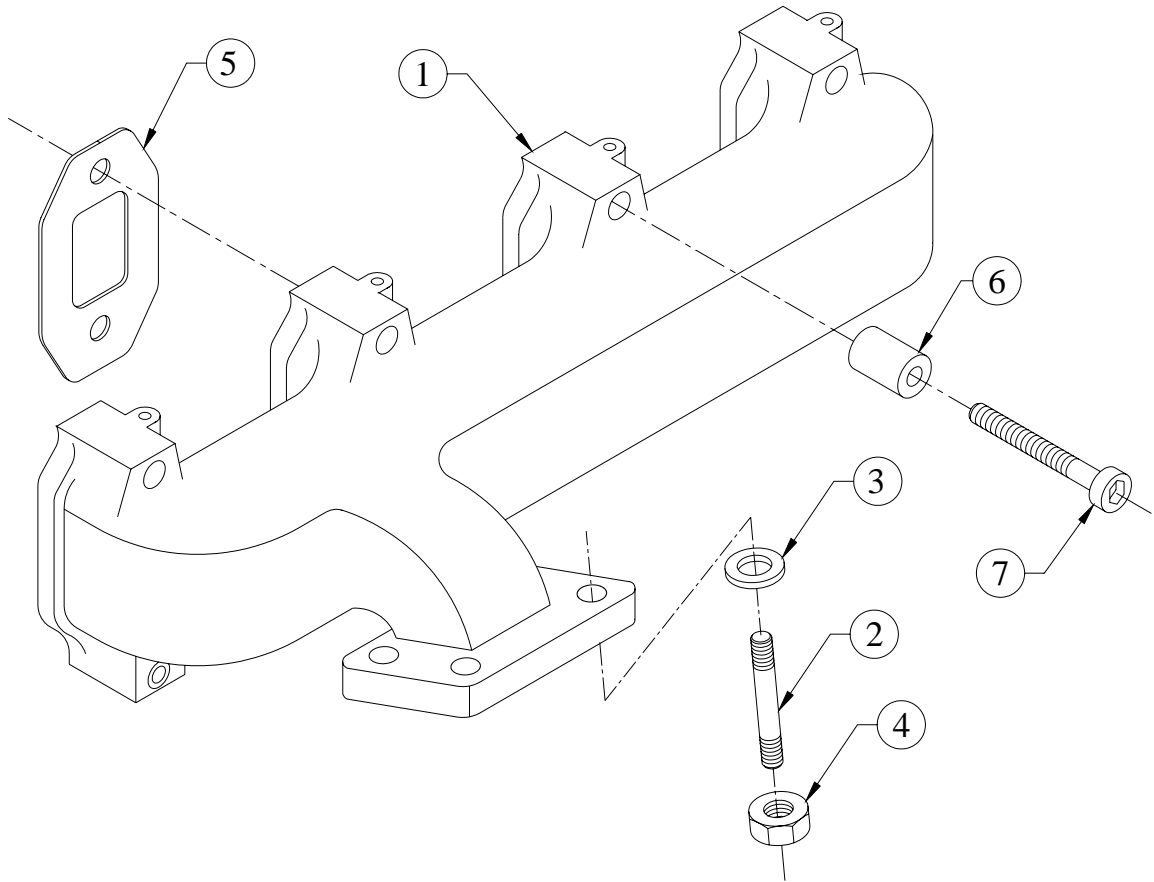

SR.NO.	PART NO.	DESCRIPTION	QTY.	REMARKS
1	4H.220.01.0.00	EXHAUST MANIFOLD (TA)	1	
2	50.010.08.025	STUD - M8X1.25X25 - 8.8	4	
3	50.506.08.000	PLAIN MACHINED WASHER - M8	4	
4	50.080.08.000	STAINLESS STEEL NUT	4	
5	4H.035.06.0.00	GASKET (FOR EXHAUST MANIFOLD)	4	
6	4H.107.02.0.00	SPACER (FOR EXT.MANIFOLD)	8	
7	4H.129.03.0.00	HEXAGONAL SOCKET HEAD CAP SCREW (COPPER COATED)	8	

**TITLE :- EXHAUST SILENCER WITH
FLANGE (RB66TA)**

GROUP :- 49.446

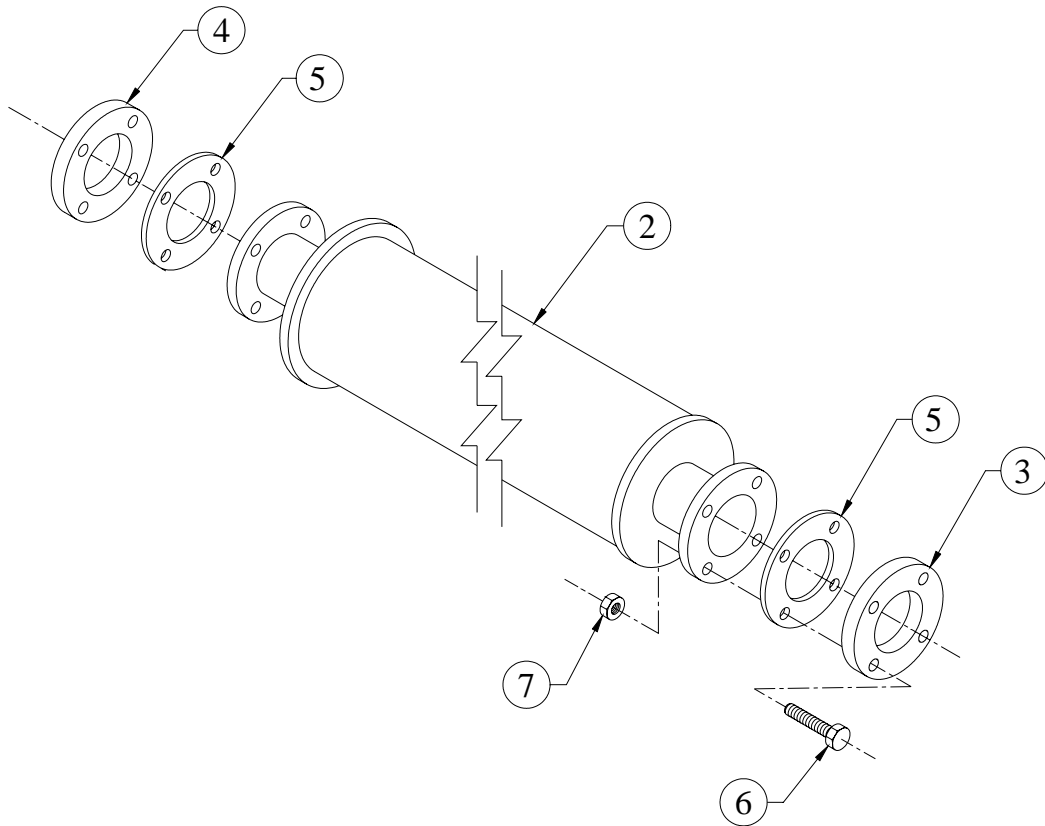

SR.NO.	PART NO.	DESCRIPTION	QTY.	REMARKS
*1	49.446.10.0.00	EXHAUST SILENCER WITH FLANGE AND JOINT	1	CONSISTING OF SR. NO.- 2 TO 7
2	F6.503.01.0.00	EXHAUST SILENCER(4" I D)	1	
3	F6.503.04.0.00	FLANGE(4" ID)	1	
4	49.446.01.0.00	FLANGE FOR EXH.SILENCER INLET	1	
5	F6.503.02.0.00	S.S.JOINT(4")	2	
6	50.003.14.040	SET SCREW - M14X2X40 - 8.8	8	
7	50.006.14.000	NUT - M14X2 - GR.8	8	

TITLE: - EXPANSIONS BELLOW (2.5" WITH TRANGELUR FLANGE 92 PCD)

GROUP: - 4H.655

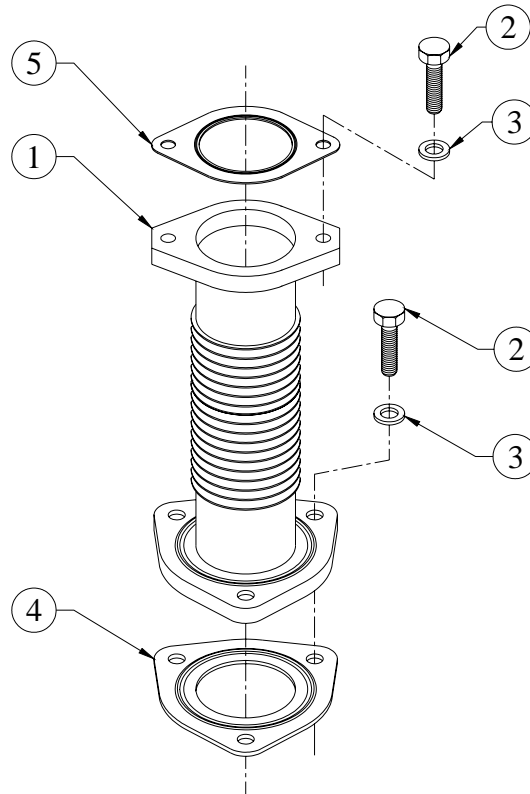

SR.NO.	PART NO.	DESCRIPTION	QTY.	REMARKS
1	4H.655.01.0.00	EXPANSION BELLOW	1	
2	50.003.08.025	SET SCREW - M8X1.25X25 - 8.8	5	
3	50.506.08.000	PLAIN MACHINED WASHER - M8	5	
4	4H.522.03.0.00	JOINT FOR EXH. DIFFUSER	1	
5	34.107.06.0.00	JOINT FOR ADAPTOR ON EX.MANIFOLD	1	

TITLE: - FLYWHEEL HOUSING (SAE3-144.5)

GROUP: - 4H.038

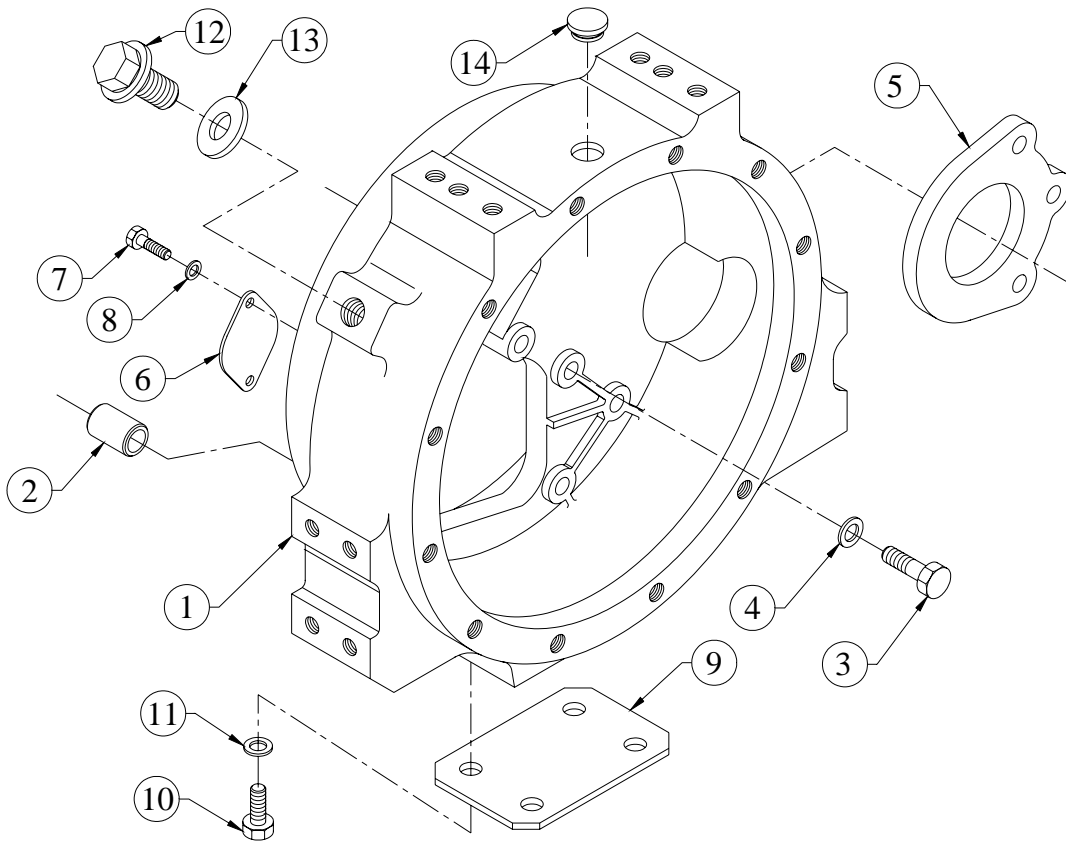

SR.NO.	PART NO.	DESCRIPTION	QTY.	REMARKS
1	4H.038.01.0.00	FLYWHEEL HOUSING (SAE3 -144.5)	1	
2	4H.001.13.0.00	HOLLOW DOWEL (16 DIA)	2	
3	50.052.10.030	SET BOLT-M10X30-10.9	10	
4	02.024.09.0.00	WASHER	10	
5	4H.038.02.0.00	FLANGE FOR STARTER.	1	
6	4H.038.04.0.00	BLANKING PLATE (FOR FLYWHEEL HOUSING)	1	
7	50.003.06.012	SET SCREW - M6X1X12 - 8.8	2	
8	50.506.06.000	PLAIN MACHINED WASHER - M6	2	
9	03.086.02.0.00	COVER FOR FLY WHEEL HSG	1	
10	50.003.08.016	SET SCREW - M8X1.25X16 - 8.8	4	
11	50.506.08.000	PLAIN MACHINED WASHER - M8	4	
12	50.602.16.000	CORE PLUG 16X1.5	1	
13	50.508.15.000	COPPER WASHER (17X23)	1	
14	F6.016.12.0.00	RUBBER CAP.	1	

TITLE: -FLYWHEEL (C-110 PTO & SP-111 PTO)

GROUP: - 04.039

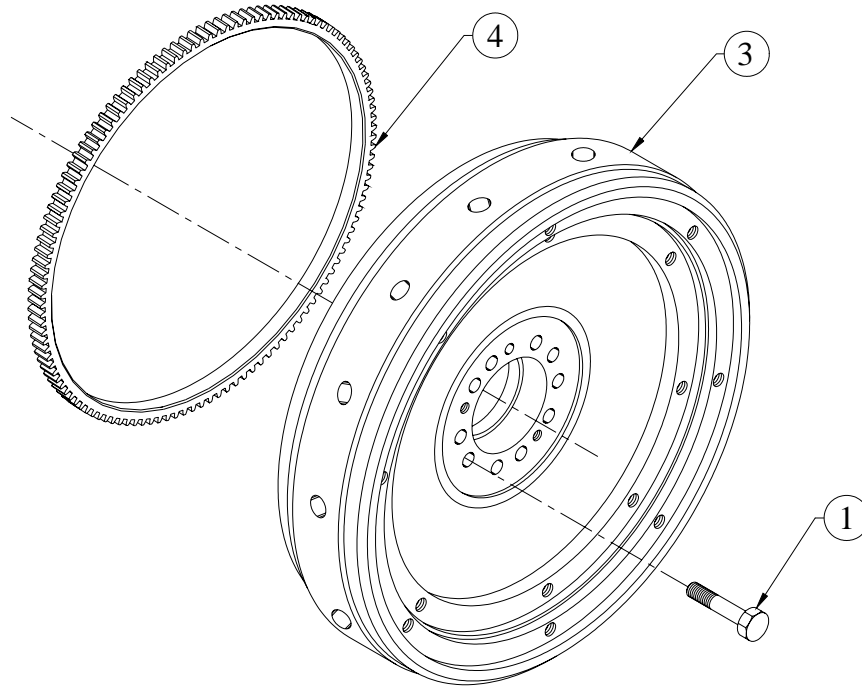

SR.NO.	PART NO.	DESCRIPTION	QTY.	REMARKS
1	03.050.02.0.00	FLYWHEEL BOLT (M10X50)	10	
*2	04.039.10.0.00	FLYWHEEL ASSLY	1	CONSISTING OF SR. NO.- 3 & 4
3	04.039.01.0.00	FLYWHEEL (C-110 PTO & SP-111 PTO)	1	
4	03.035.02.0.00	STARTER RING HA	1	

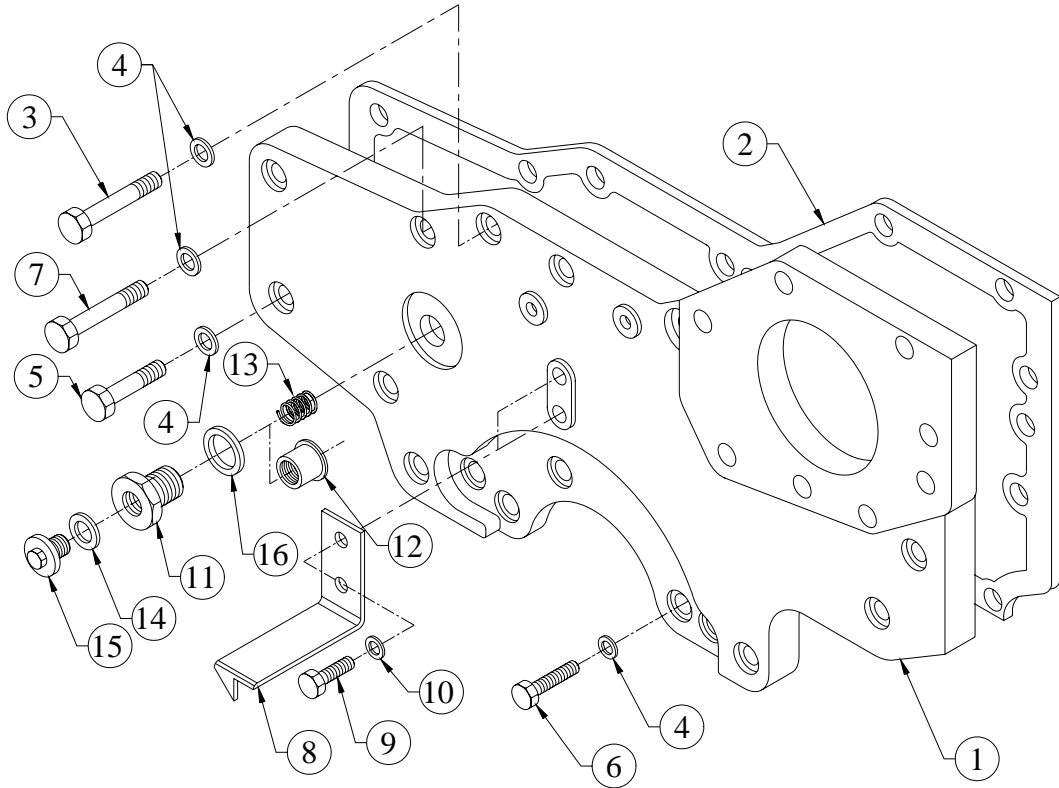
TOTAL: - FRONT COVER FOR PG APPLICATION**GROUP: - 4H.179...EXP**

SR.NO.	PART NO.	DESCRIPTION	QTY.	REMARKS
1	4H.179.01.0.00	FRONT COVER (W/O HYD. PUMP MNTG.)	1	
2	2H.037.11.0.00	JOINT (FRONT COVER)	1	
3	50.002.08.100	SET BOLT - M8X1.25X100 - 8.8	4	
4	50.506.08.000	PLAIN MACHINED WASHER - M8	18	
5	50.002.08.030	SET BOLT - M8X1.25X30 - 8.8	4	
6	50.003.08.025	SET SCREW - M8X1.25X25 - 8.8	5	
7	50.002.08.035	SET BOLT - M8X1.25X35 - 8.8	5	
8	2H.037.06.0.00	TIMING POINTER	1	
9	50.003.06.012	SET SCREW - M6X1X12 - 8.8	2	
10	50.506.06.000	PLAIN MACHINED WASHER - M6	2	
11	03.117.04.0.00	ADAPTOR (FOR TD UNIT)	1	
12	03.014.07.0.00	CUP FOR SPRING	1	
13	03.014.06.0.00	SPRING FOR CUP	1	
14	50.508.27.000	COPPER WASHER (24X29)	1	
15	34.001.11.0.00	DRAIN PLUG (F)	1	
16	50.508.16.000	COPPER WASHER (18 X 22)	1	

TITLE:- FUEL FILTER MOUNTING FOR SPIN ON FILTER (SHANTI)

GROUP:- 4H.657

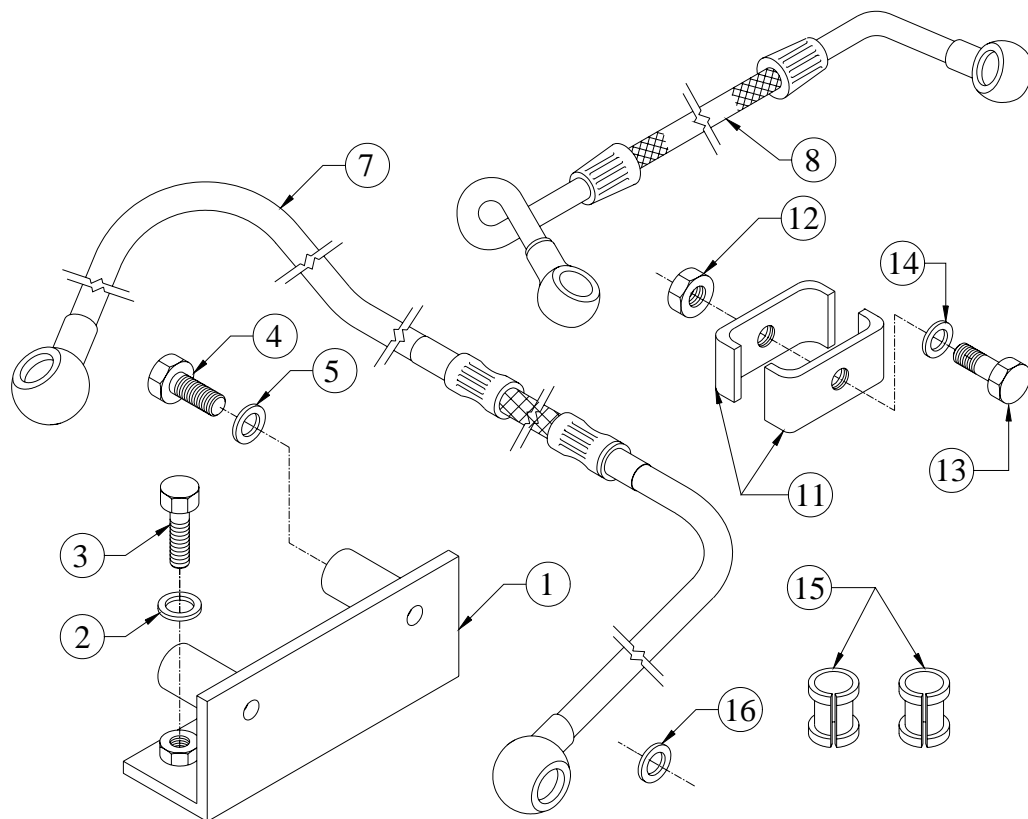

SR.NO.	PART NO.	DESCRIPTION	QTY.	REMARKS
1	3H.191.01.0.00	FUEL FILTER MOUNTING SPIN ON TYPE 1.1 LIT	1	
2	50.506.10.000.	PLAIN MACHINED WASHER - M10	2	
3	50.002.10.045.	SET BOLT - M10X1.5X45 - 8.8	2	
4	50.003.12.035.	SET SCREW - M12X1.75X35 - 8.8	2	
5	50.506.12.000.	PLAIN MACHINED WASHER - M12	2	
*6	4H.657.10.0.00	SUB ASSEMBLY OF FUEL PIPES	1	CONSISTING OF SR. NO.- 7 TO 9 & 15
7	4H.657.01.0.PR	FUEL PIPE-FUEL FILTER TO FUEL PUMP	1	
8	4H.031.05.0.00	FUEL PIPE (FEED PUMP TO FILTER)	1	
*9	4H.031.30.0.00	CLAMP ASSEMBLY (WITHO UT RUBBER SLEEVE)	1	CONSISTING OF SR. NO.- 10, 11,13 & 14
*10	4H.031.10.0.00	CLAMP SUB ASSLY	1	CONSISTING OF SR. NO.- 11 & 12

TITLE:- FUEL FILTER MOUNTING FOR SPIN ON FILTER (SHANTI)

GROUP:- 4H.657

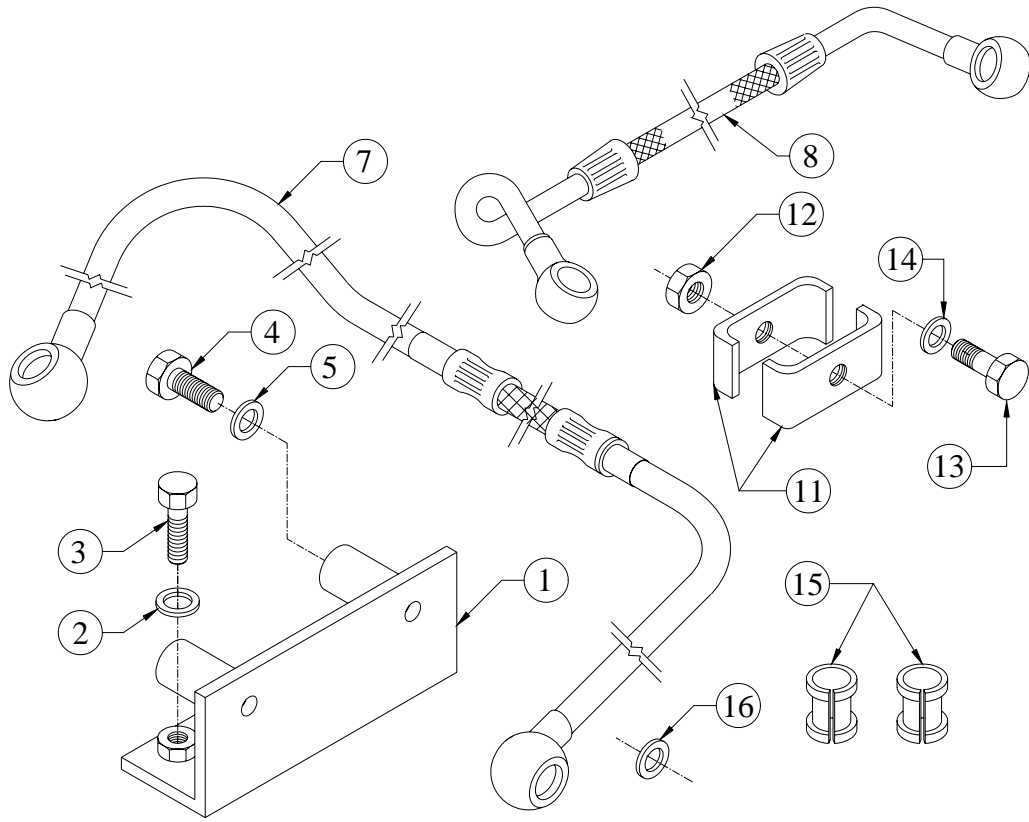

SR.NO.	PART NO.	DESCRIPTION	QTY.	REMARKS
11	4H.031.06.0.00	CLAMP	2	
12	50.006.06.000.	NUT – M6X1 - GR.8	1	
13	50.003.06.025.	SET SCREW - M6X1X25 - 8.8	1	
14	50.506.06.000.	PLAIN MACHINED WASHER - M6	1	
15	4H.031.07.0.00	RUBBER SLEEVE	2	
16	50.548.12.0.00	WASHWR	4	

**TITLE :- FUEL PUMP 4RTA
(NON ASBESTOS JOINT)**

GROUP :- 4H.240...EXP

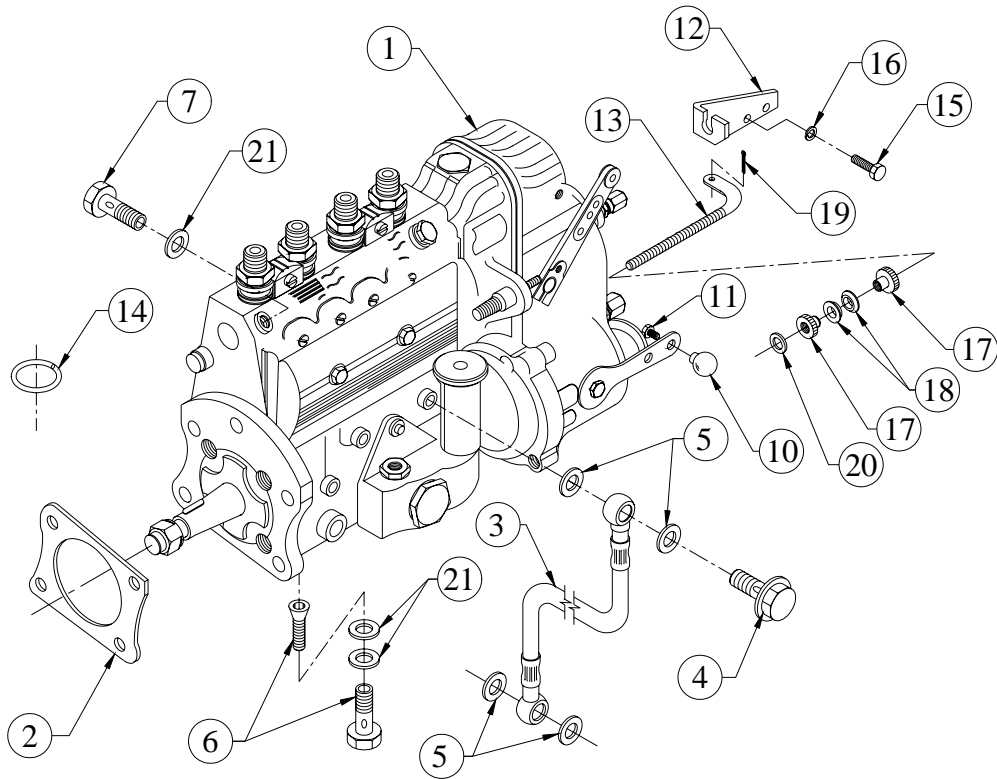

SR.NO.	PART NO.	DESCRIPTION	QTY.	REMARKS
1	4H.240.10.0.00	FUEL PUMP 4R1040 TA ENGINE	1	
2	34.016.12.0.00	JOINT FOR FUEL PUMP (NON ASBESTOS)	1	
3	4H.006.01.0.00	L.O.SUPPLY HOSE (FIP)	1	
4	03.660.07.0.00	SPECIAL BANJO BOLT (L.O.SUPPLY TO PUMP)	2	
5	50.508.07.000	COPPER WASHER (10X14)	4	
6	34.016.15.0.00	BANJO BOLT WITH STRAINER (2 443 456 900)	1	
7	50.504.04.000.	BANJO BOLT - M14X1.5	2	
*8	10.027.02.0.00	LEAD SEAL (5945010300)	1	NOT ILLUSTRATED
*9	10.027.03.0.00	SEALING WIRE (5945010600)	1	NOT ILLUSTRATED
10	51.509.25.0.00	KNOB FOR HANDLE	1	
11	50.003.06.012.	SET SCREW - M6X1X12 - 8.8	1	
12	4H.122.01.0.00	BRACKET FOR SPEED ADJUSTMENT	1	

HERICAL WAS E

TITLE :- FUEL PUMP GEAR

GROUP :- 2H.011

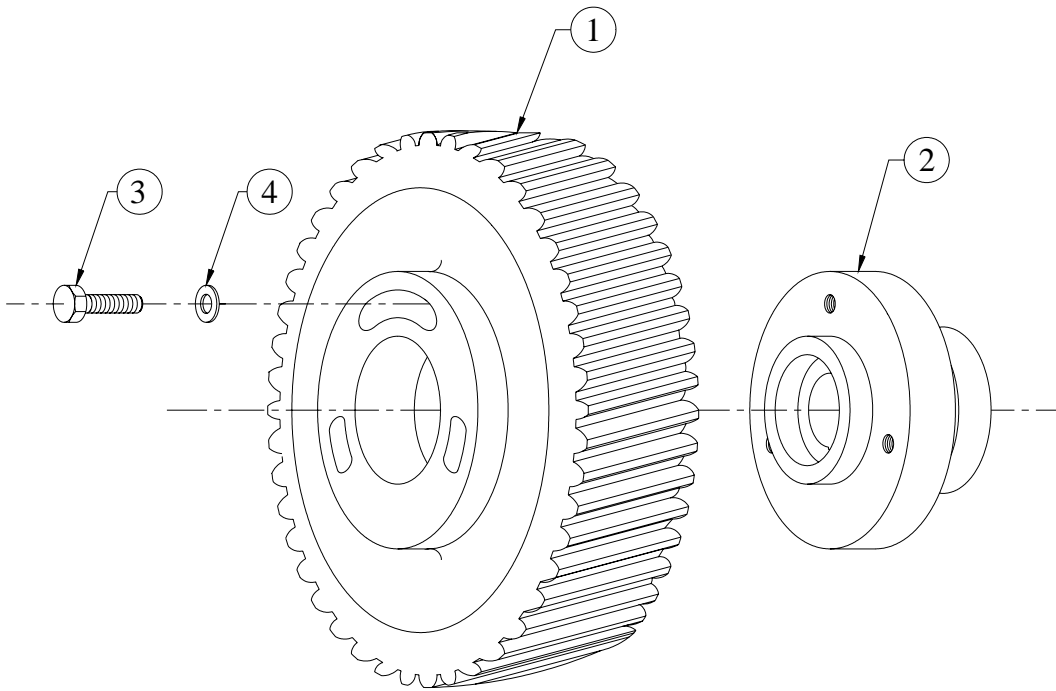

SR.NO.	PART NO.	DESCRIPTION	QTY.	REMARKS
1	2H.011.01.0.00	FUEL PUMP GEAR (FINISH)	1	
2	2H.011.02.0.00	HUB FOR FUEL PUMP GEAR (FINISH)	1	
3	50.003.08.025	SET SCREW - M8X1.25X25 - 8.8	3	
4	34.017.05.0.00	WASHER FOR FUEL PUMP GEAR	3	

TITLE: - GEAR CASING WITH DEFLECTOR

GROUP: - 4H.1074...EXP

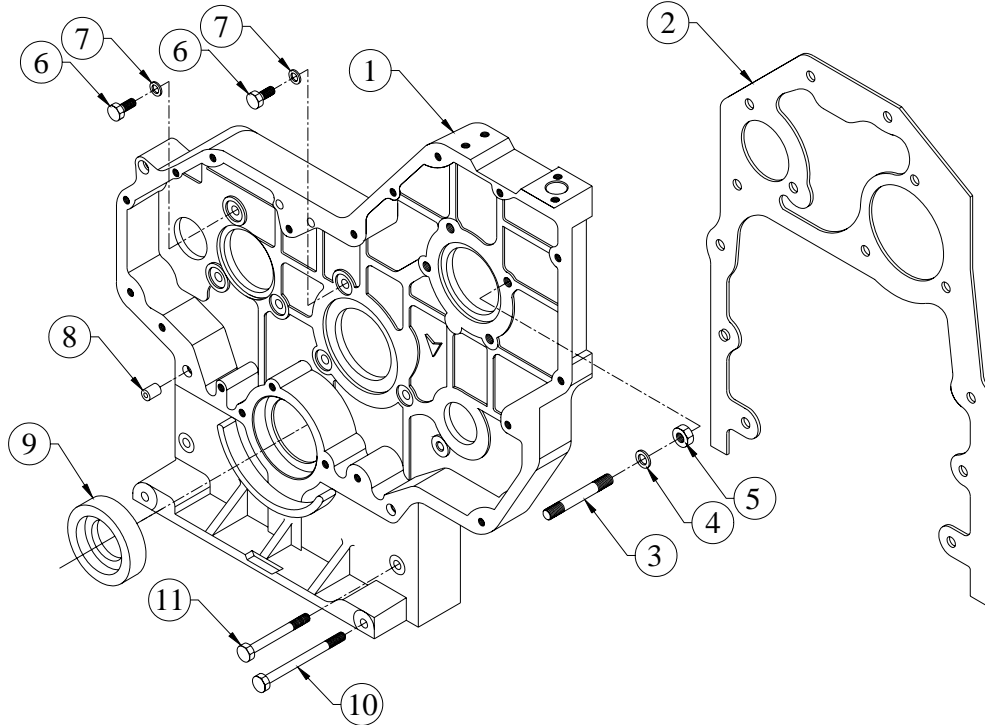

SR.NO.	PART NO.	DESCRIPTION	QTY.	REMARKS
1	4H.178.02.0.00	GEAR CASING (MACHINING)	1	
2	2H.005.11.0.00	JOINT FOR GEAR COVER	1	
3	50.010.10.030	STUD - M10X1.5X30 - 8.8	4	
4	03.001.25.0.00	WASHER (FOR FUEL PUMP MTG)	4	
5	50.006.10.000	NUT - M10X1.5 - GR.8	4	
6	50.003.08.025	SET SCREW - M8X1.25X25 - 8.8	6	
7	50.506.08.000	PLAIN MACHINED WASHER - M8	10	
8	34.001.23.0.00	DOWEL FOR GEAR CASING	2	
9	03.013.06.0.00	OIL SEAL (65X85X13)(CR MAKE)	1	
10	50.002.08.110	SET BOLT - M8X1.25X110 - 8.8	2	
11	50.002.08.080	SET BOLT - M8X1.25X80 - 8.8	2	

TITLE:- HIGH PRESSURE PIPE (700 MM)

GROUP:- 4H.050

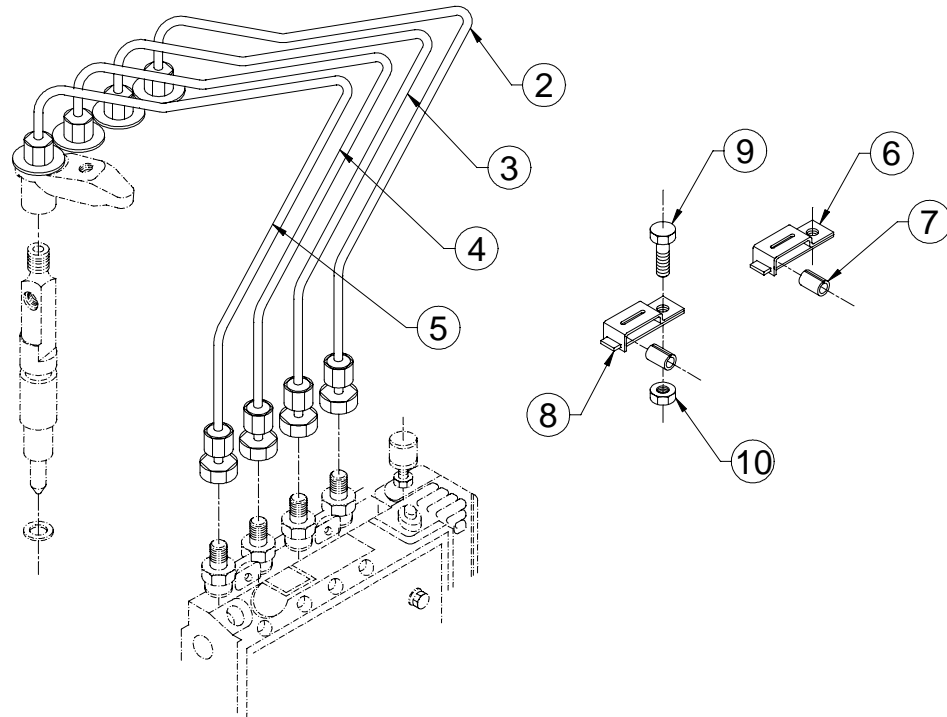

SR.NO.	PART NO.	DESCRIPTION	QTY.	REMARKS
*1	4H.050.60.0.00	H.P.PIPE COMPLETE SET (700 MM)	1	CONSISTING OF SR. NO.- 2 TO 10
2	4H.050.20.0.00	H.P.PIPE ASSLY.BEND, 700 MM, CYL.NO.1	1	
3	4H.050.30.0.00	H.P.PIPE ASSLY, BEND, 700 MM, CYL.NO.2	1	
4	4H.050.40.0.00	H.P.PIPE ASSLY.BEND, 700 MM, CYL.NO.3	1	
5	4H.050.50.0.00	H.P.PIPE ASSLY, BEND, 700 MM, CYL.NO.4	1	
6	50.541.02.000	PIPE CLIP. (FOR 3 PIPES)	1	
7	02.036.03.0.00	RUBBER SLEEVE	7	
8	50.541.03.000	PIPE CLIP (FOR 4 PIPES)	1	
9	50.003.06.012	SET SCREW - M6X1X12 - 8.8	2	
10	50.006.06.000	NUT - M6X1 - GR.8	2	

**TITLE: -INJECTOR & MTG.
(TURBOCHARGED ENGINE)**

GROUP: - 4H.154

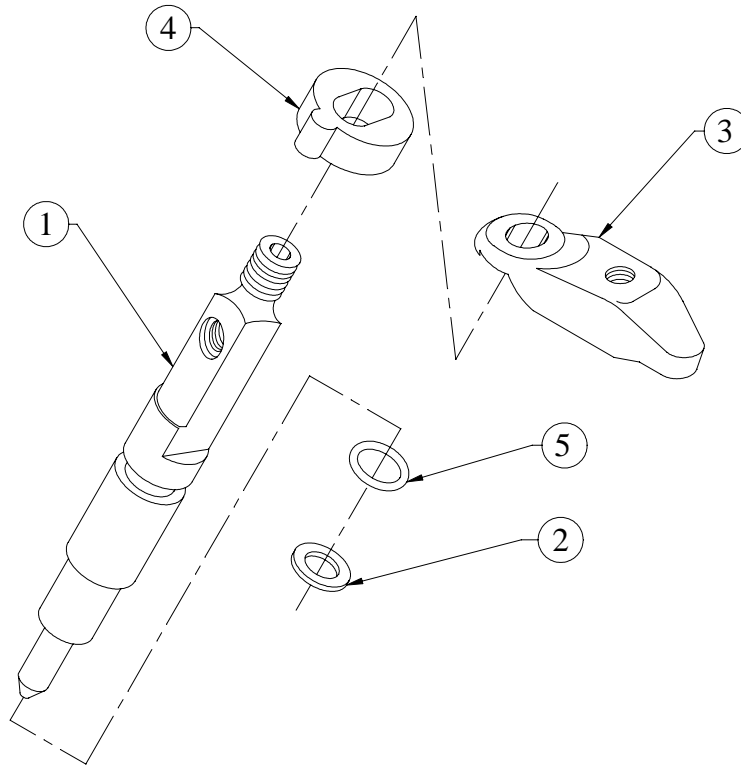

SR.NO.	PART NO.	DESCRIPTION	QTY.	REMARKS
1	4H.154.10.0.00	INJECTOR ASSLY (V.S.TURBOCHARGED ENGINE)	1	
2	10.029.07.0.00	WASHER FOR INJ. (2439999032)	1	
3	2H.023.01.0.00	INJECTOR YOKE.	1	
4	02.035.08.0.00	BUSH FOR INJECTOR	1	
5	3H.009.11.0.00	O RING FOR NOZZLE	1	

**TITLE :- INTERMEDIATE GEAR AND SUPPORT
(FOR ENGINE W/O AUTOTIMER)**

GROUP :- 4H.237

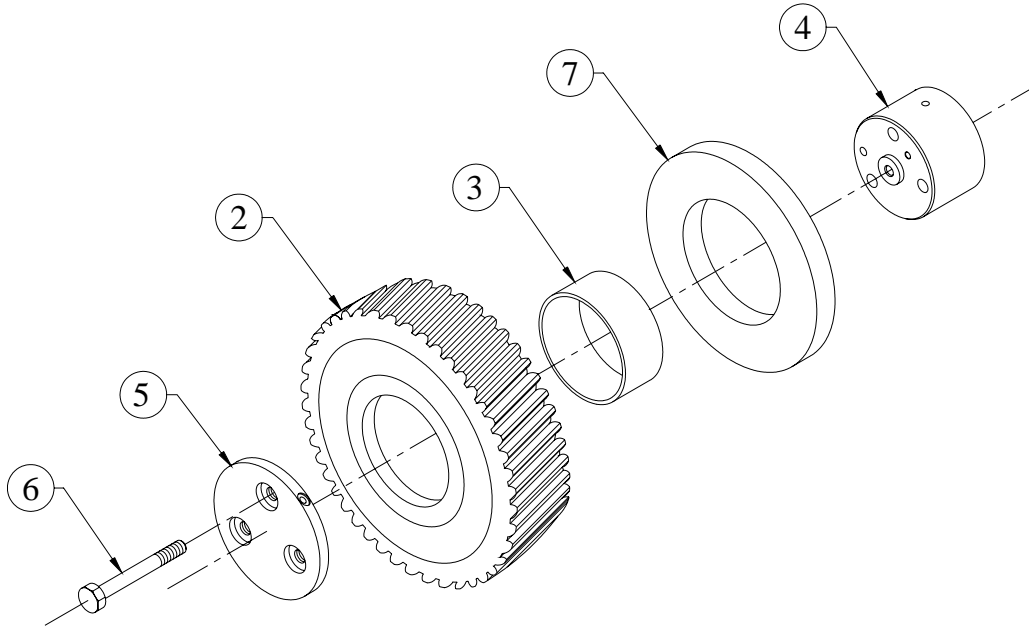

SR.NO.	PART NO.	DESCRIPTION	QTY.	REMARKS
*1	2H.038.10.0.00	ASSLY OF INTERMEDIATE GEAR & BUSH	1	CONSISTING OF SR.NO.2 & 3
2	2H.038.03.0.00	INTERMEDIATE GEAR (FINISH)	1	
3	2H.004.02.9.00	BUSH FOR INTERMEDIATE GEAR (S/F)	1	
4	4H.237.01.0.00	INTERMEDIATE GEAR SUPPORT (TURBO W/O AUTOTIMER)	1	
5	2H.004.04.0.00	RETAINING PLATE (FOR INT.GEAR)	1	
6	50.002.08.070	SET BOLT - M8X1.25X70 - 8.8	3	
7	2H.038.02.0.00	THRUST WASHER	1	

TITLE:- LEAK OFF PIPE (4R 1040 TA ENGINE SHANTI PROJECT)

GROUP:- 4H.516

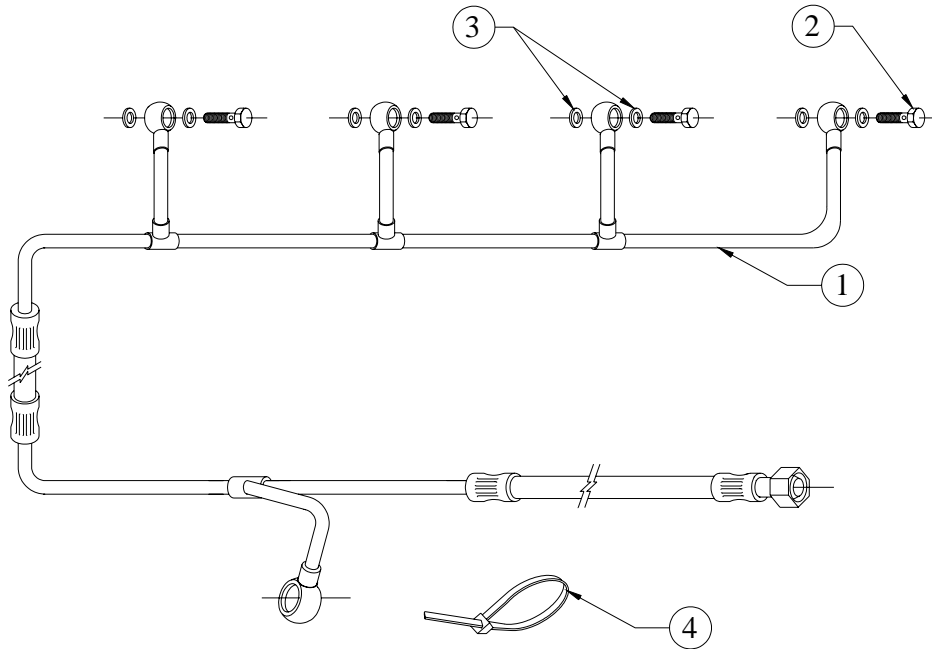

SR.NO.	PART NO.	DESCRIPTION	QTY.	REMARKS
1	4H.516.10.0.00	NOZZLE LEAK OFF SUB ASSEMBLY	1	
2	03.027.04.0.00	BANJO BOLT	4	
3	4H.010.93.0.00	MICO COPPER WASHER FOR LEAK OFF PIPE (MICO NO. 2 916 710 603)	8	
4	4H.010.24.0.00	PLASTIC CLAMP	1	

TITLE :- LIFTING HOOK (TURBO ENGINE)

GROUP :- 4H.170

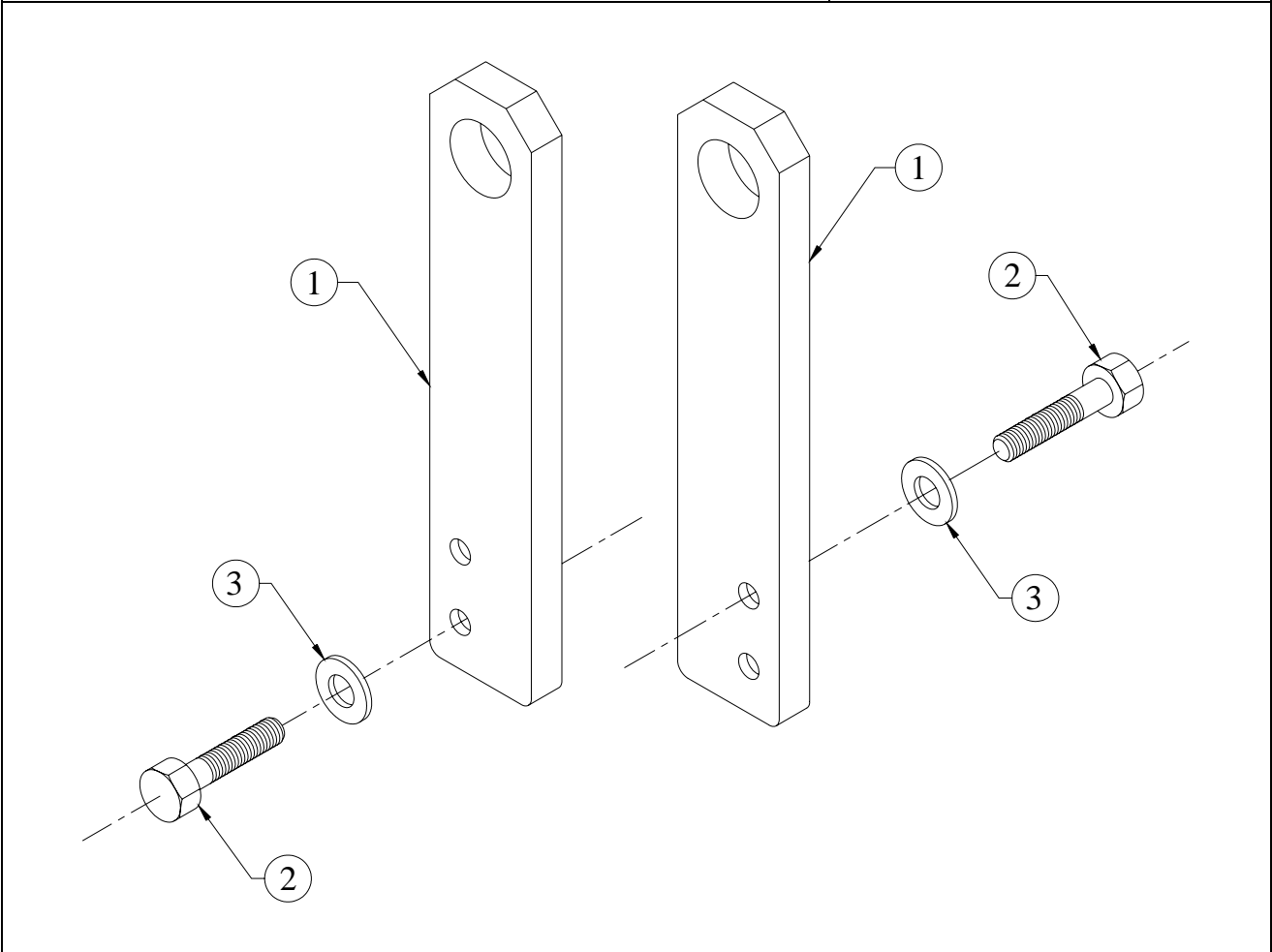

SR.NO.	PART NO.	DESCRIPTION	QTY.	REMARKS
1	4H.170.01.0.00	LIFTING HOOK	2	
2	50.002.10.025	SET BOLT	4	
3	50.506.10.0.00	PLAIN MACHINED WASHER	4	

TITLE:- LUB OIL COOLER AND SPIN ON FILTER [USA]

GROUP:- 4H.144...EXP

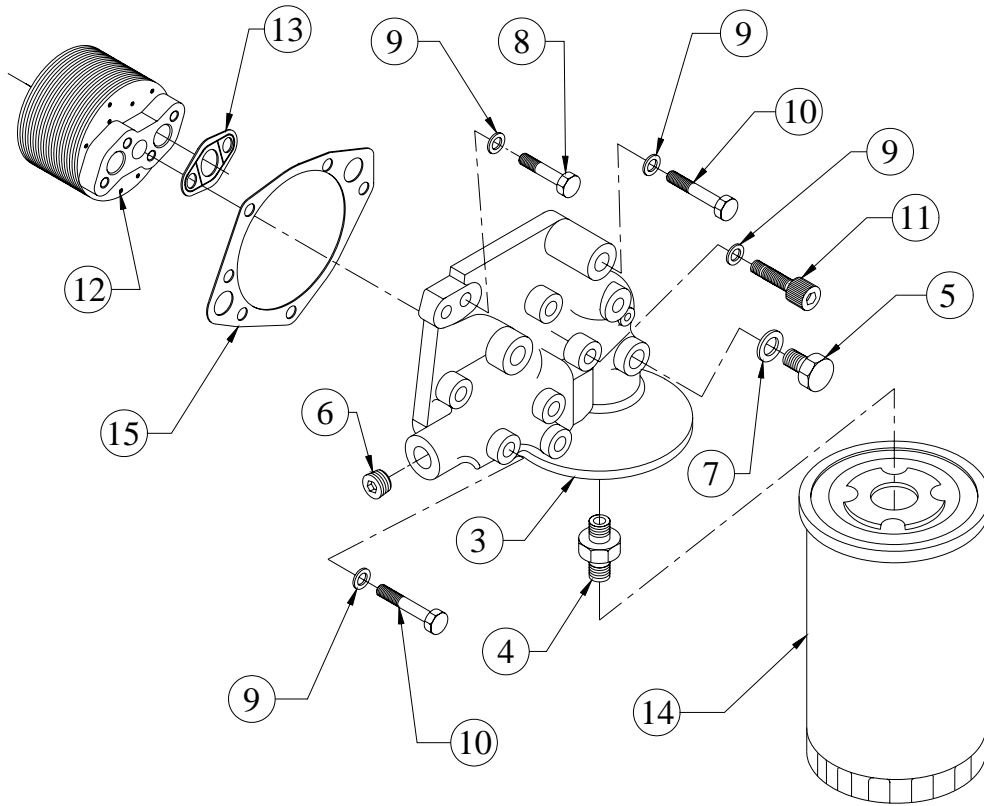

SR.NO.	PART NO.	DESCRIPTION	QTY.	REMARKS
*1	4H.144.30.0.00	ASSEMBLY OF LUB OIL FILTER HEADER AND COOLER	1	CONSISTING OF SR. NO. 2 & 8 TO 13
*2	4H.144.20.0.00	HEADER SUB ASSLY(L.O.FILTER)	1	CONSISTING OF SR. NO. 3 TO 7
3	4H.385.01.0.00	HEADER (FOR L.O.AND SPIN ON FILTER)	1	
4	3H.007.05.0.00	ADAPTOR FOR SPIN ON FILTER	1	
5	34.001.09.0.00	PLUG FOR OIL GALLERY	1	
6	50.056.06.000.	HEADLESS PIPE PLUG 1/2"-14 NPTF	2	
7	50.565.10.000.	INTERNAL RUBBER LIP SEALING WASHER -M10- FOR FUEL LINES	1	
8	50.002.08.070.	SET BOLT - M8X1.25X70 - 8.8	1	
9	50.506.08.000.	PLAIN MACHINED WASHER - M8	6	
10	50.002.08.090.	SET BOLT - M8X1.25X90 - 8.8	5	
11	50.011.08.035.	SOCKET HEAD SCREW - M8X1.25X35 - 8.8	4	

TITLE:- LUB OIL COOLER AND SPIN ON FILTER [USA]

GROUP:- 4H.144...EXP

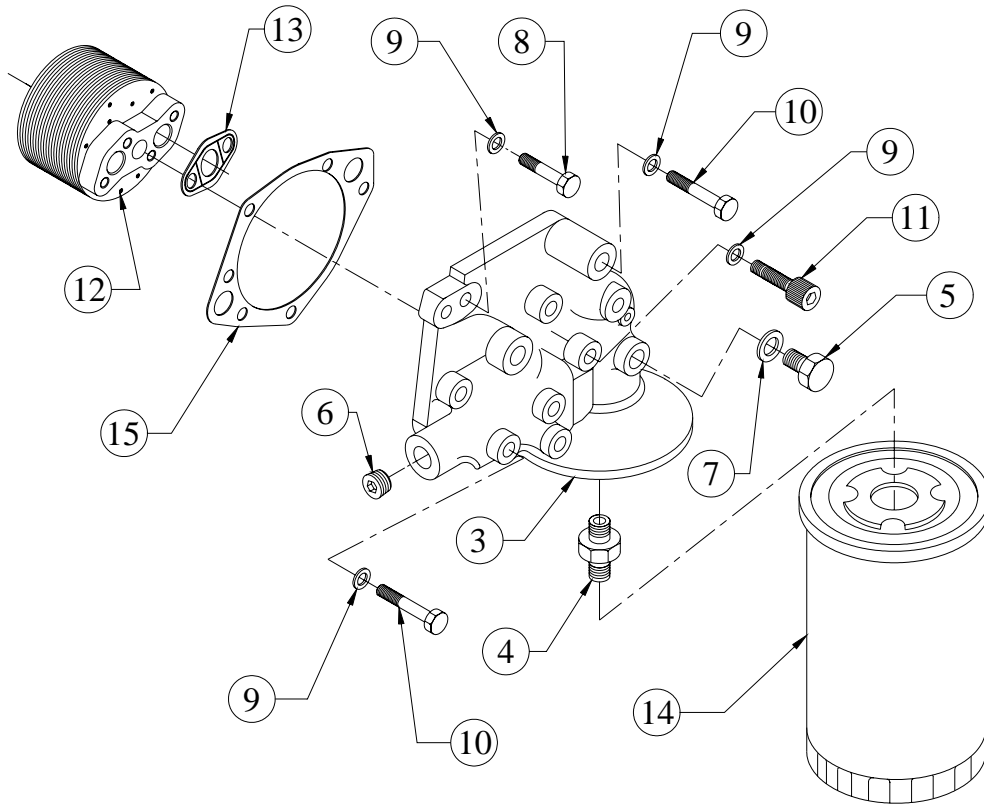

SR.NO.	PART NO.	DESCRIPTION	QTY.	REMARKS
12	4H.385.02.0.00	LUB OIL COOLER (12 PLATES)	1	
13	3H.007.13.0.00	JOINT FOR LUB OIL COOLER (NON ASBESTOS GASKET)	1	
14	06.436.01.0.00	SPIN ON FILTER FOR LUBRICATING OIL	1	
15	3H.007.15.0.00	JOINT FOR HEADER	1	

TITLE:- LUB OIL PUMP

GROUP:- 6H.004

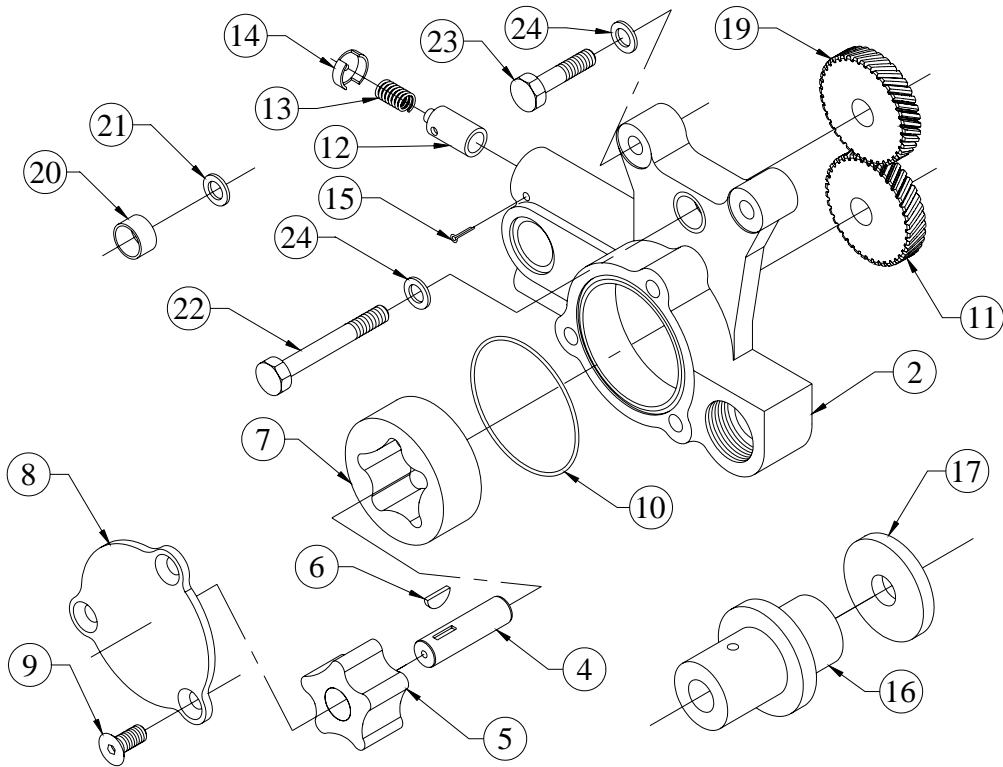

SR.NO.	PART NO.	DESCRIPTION	QTY.	REMARKS
*1	6H.004.10.0.00	LUBE.OIL PUMP ASSEMBLY.	1	CONSISTING OF SR. NO. 2, 3 & 7 TO 15
2	6H.004.20.0.00	SUB. ASSEMBLY OF L.O.PUMP BODY & BUSH.	1	
*3	06.010.10.0.00	ROTOR ASSLY	1	CONSISTING OF SR. NO. 4, 5 & 6
4	06.010.03.0.00	SHAFT	1	
5	06.010.04.0.00	INNER ROTOR	1	
6	50.405.11.000.	WOODRUFF KEY	1	
7	06.010.05.0.00	OUTER ROTOR	1	
8	06.010.02.0.00	COVER PLATE	1	
9	06.010.01.0.00	COUNTER SUNK SOCKET HEAD SCREW.	3	
10	03.010.11.0.00	O RING - L.O.PUMP (1.57X65, 21508)	1	
11	3H.005.04.0.00	LUB.OIL PUMP DRIVING GEAR (FINISH)	1	
12	03.010.13.0.00	RELIEF VALVE	1	

TITLE:- LUB OIL PUMP

GROUP:- 6H.004

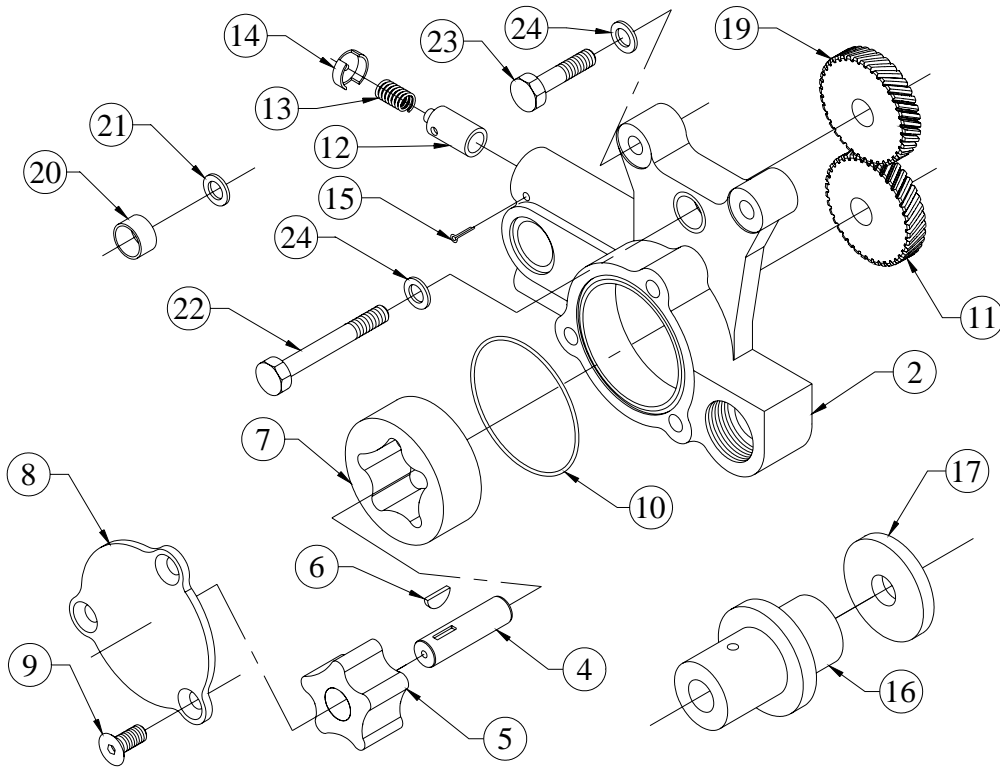

SR.NO.	PART NO.	DESCRIPTION	QTY.	REMARKS
13	03.010.14.0.00	SPRING FOR RELIEF VALVE	1	
14	03.010.15.0.00	CUP FOR SPRING	1	
15	50.036.07.010.	SPLIT COTTER PIN - 1/8"X1-1/2"	1	
16	4H.372.01.0.00	SHAFT FOR LUB OIL PUMP (INTERMEDIATE GEAR)	1	
17	4H.372.02.0.00	HARD WASHER (FOR INT. GEAR)	1	
*18	3H.005.30.0.00	SUB.ASSLY.OF L.O.PUMP INT.GEAR AND BUSH.	1	CONSISTING OF SR. NO. 19, 20
19	3H.005.03.0.00	INTERMEDIATE GEAR (FOR L.O.PUMP)(FINISH)	1	
20	34.014.12.0.00	BUSH FOR LEVER	1	
21	02.024.38.0.00	WASHER (ROCKER LEVER)	1	
22	50.002.08.075.	SET BOLT - M8X1.25X75 - 8.8	1	
23	50.002.08.035.	SET BOLT - M8X1.25X35 - 8.8	2	
24	50.506.08.000.	PLAIN MACHINED WASHER - M8	3	

TITLE:- LUB OIL SUMP (FOR CCV VALVE)

GROUP:- 4H.1209

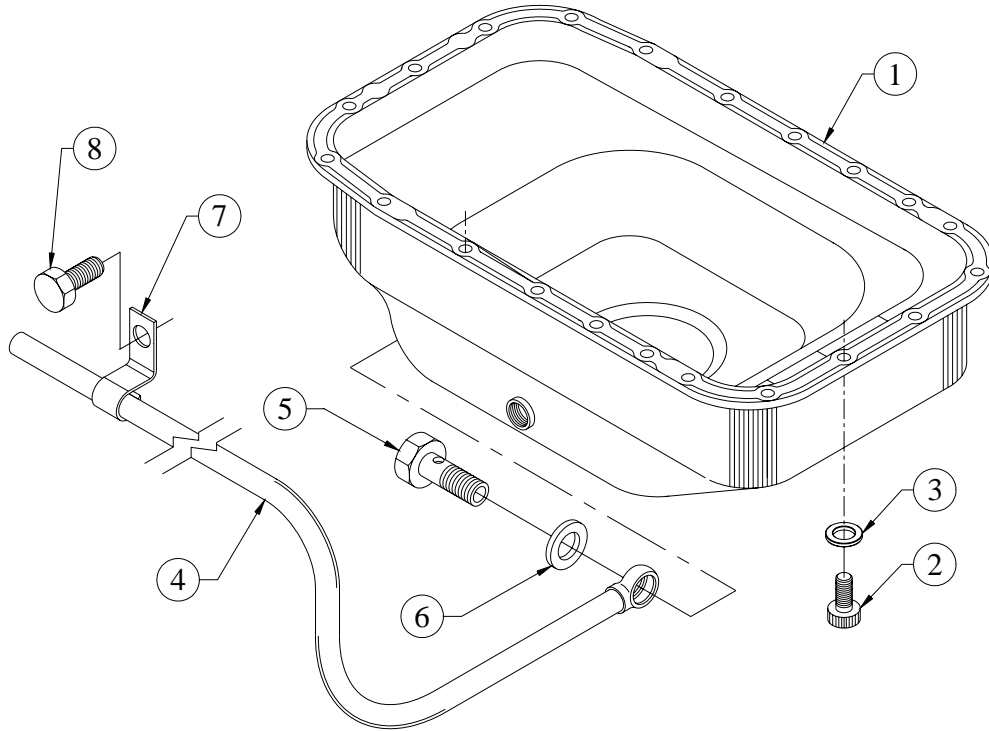

SR.NO.	PART NO.	DESCRIPTION	QTY.	REMARKS
1	4H.1209.10.0.PR	LUB OIL SUMP (FOR CCV VALVE)	1	
2	50.011.08.016	SOCKET HEAD SCREW - M8X1.25X16 - 8.8	21	
3	06.074.16.0.00	WASHER (SHEET METAL L.O.SUMP)	21	
4	4H.1209.20.0.PR	SUB ASM. OF STEEL TUBE WITH BANJO	1	
5	50.504.06.000	BANJO BOLT - M18X1.5	1	
6	50.508.17.000	COPPER WASHER (18X24)	2	
7	4H.1209.01.0.PR	CLIP FOR STEEL TUBE	1	
8	50.003.12.020	SET SCREW - M12X1.75X20 - 8.8	2	

**TITLE: - STARTER 12VDC 2.7KW MICO
SUITABLE FOR 30°C**

GROUP: - 2H.301

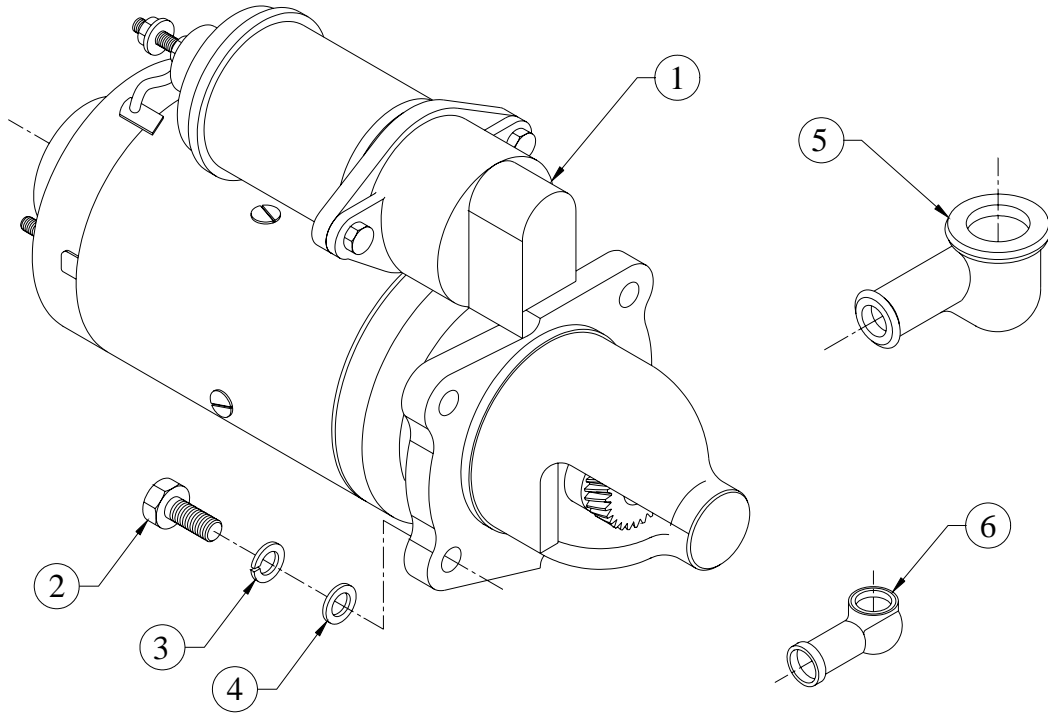

SR.NO.	PART NO.	DESCRIPTION	QTY.	REMARKS
1	2H.301.01.0.00	MICO STARTER 12VDC 2.7KW SUITABLE FOR -20°C TYPE NO.9000033009 DEL 114L	1	
2	50.003.10.030.	SET SCREW - M10X1.5X30 - 8.8	3	
3	50.505.10.000.	SPRING WASHER - M10	3	
4	50.506.10.000.	PLAIN MACHINED WASHER - M10	3	
5	24.083.01.0.00	RUBBER SLEEVE (20DIA)	1	
6	22.118.01.0.00	RUBBER SLEEVE (12DIA)	1	

**TITLE: - MONOBLOCK CRANKCASE
(4RT - EXPORT)**

GROUP: - 4H.156...EXP

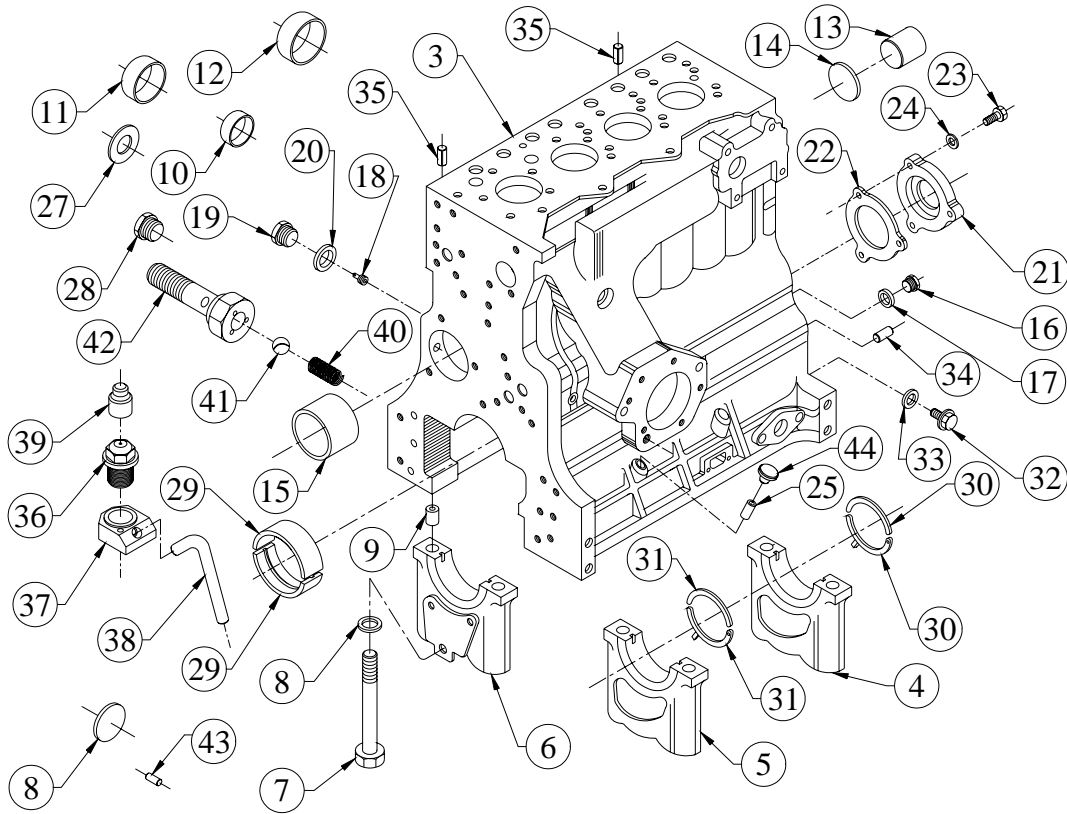

SR.NO.	PART NO.	DESCRIPTION	QTY.	REMARKS
*1	4H.156.60.0.00	CRANKCASE ASSEMBLY (USA)	1	CONSISTING OF SR NO. 2,15 TO 28
*2	4H.156.50.0.00	CRANKCASE (LINE BORING OPERATION)	1	CONSISTING OF SR NO. 3 TO 14
3	4H.156.01.0.00	CRANKCASE (TURBOCHARGED ENGINE)	1	
4	03.001.23.0.00	M.B.CAP (FWE) 16.99 DIA.DOWEL HOLE	1	
5	03.001.24.0.00	M.B.CAP (KHD) 16.99DIA DOWEL HOLES	3	
6	4H.001.02.0.00	BEARING CAP (GEAR END) (FINISH)	1	
7	03.001.22.0.00	BOLT FOR MB CAP (HEX HEAD) M14X2X128	10	
8	02.001.04.0.00	WASHER	10	
9	B2.005.16.0.00	HOLLOW DOWEL (M.B.CAP)	10	
10	F6.007.34.0.00	SEALING CAP	5	

TITLE: - MONOBLOCK CRANKCASE
(4RT - EXPORT)

GROUP: - 4H.156...EXP

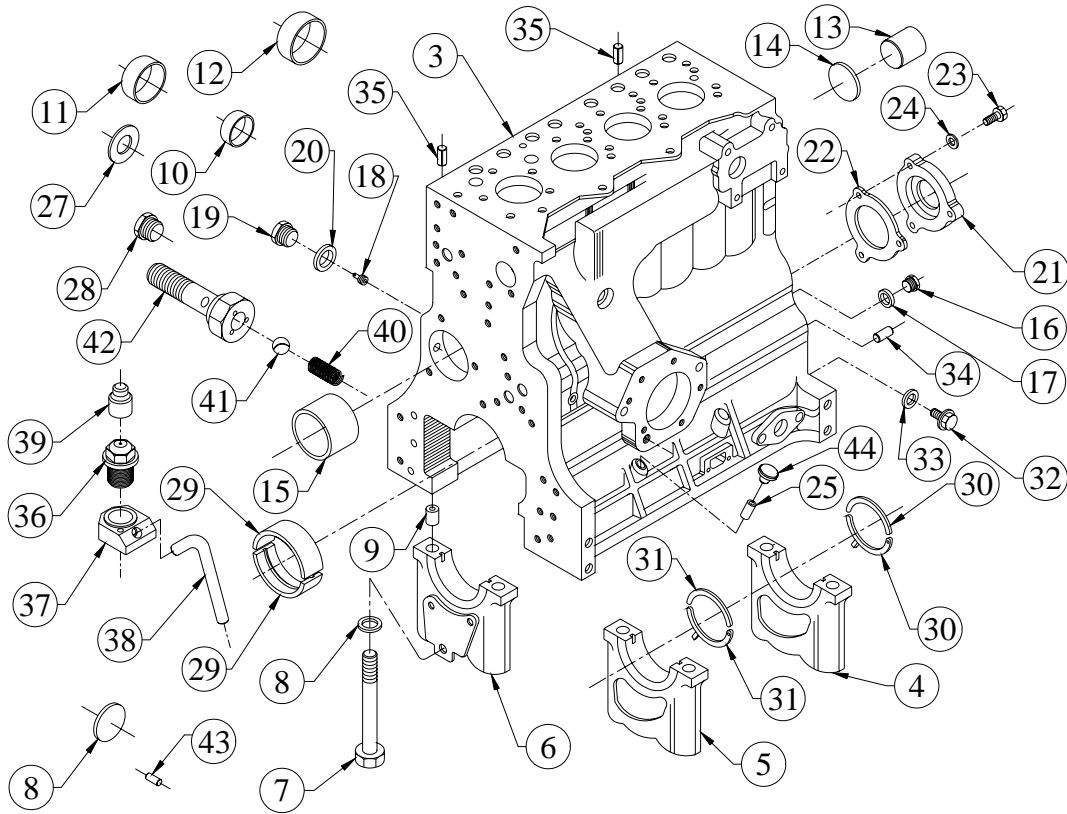

SR.NO.	PART NO.	DESCRIPTION	QTY.	REMARKS
11	F6.001.58.0.00	SEALING CAP.(40 DIN 443)	2	
12	4H.001.05.0.00	SEALING CAP (52 DIN 443)	3	
13	34.003.07.0.00	CRANK SHAFT PLUG – ALUMINIUM	2	
14	34.003.08.0.00	WASHER FOR ALU.PLUG.	2	
15	03.001.04.0.00	CAM BUSH	1	
16	04.001.04.0.00	SCREW PLUG (M20 X 1.5)	1	
17	50.508.18.000.	COPPER WASHER (20X24)	1	
18	03.001.07.0.00	SLOTTED PIN	5	
19	50.610.12.000.	CORE PLUG	5	
20	50.565.12.000.	INTERNAL RUBBER LIP SEALING WASHER -M12- FOR FUEL LINES	5	
21	4H.001.03.0.00	BLANKING PLATE FOR CAM BORE	1	
22	4H.001.14.0.00	JOINT FOR CAM BORE BLANKING PLATE	1	
23	50.003.08.025.	SET SCREW - M8X1.25X25 - 8.8	3	
24	50.506.08.000.	PLAIN MACHINED WASHER - M8	3	
25	02.037.04.0.00	DIPSTICK GUIDE	1	

TITLE: - MONOBLOCK CRANKCASE
(4RT - EXPORT)

GROUP: - 4H.156...EXP

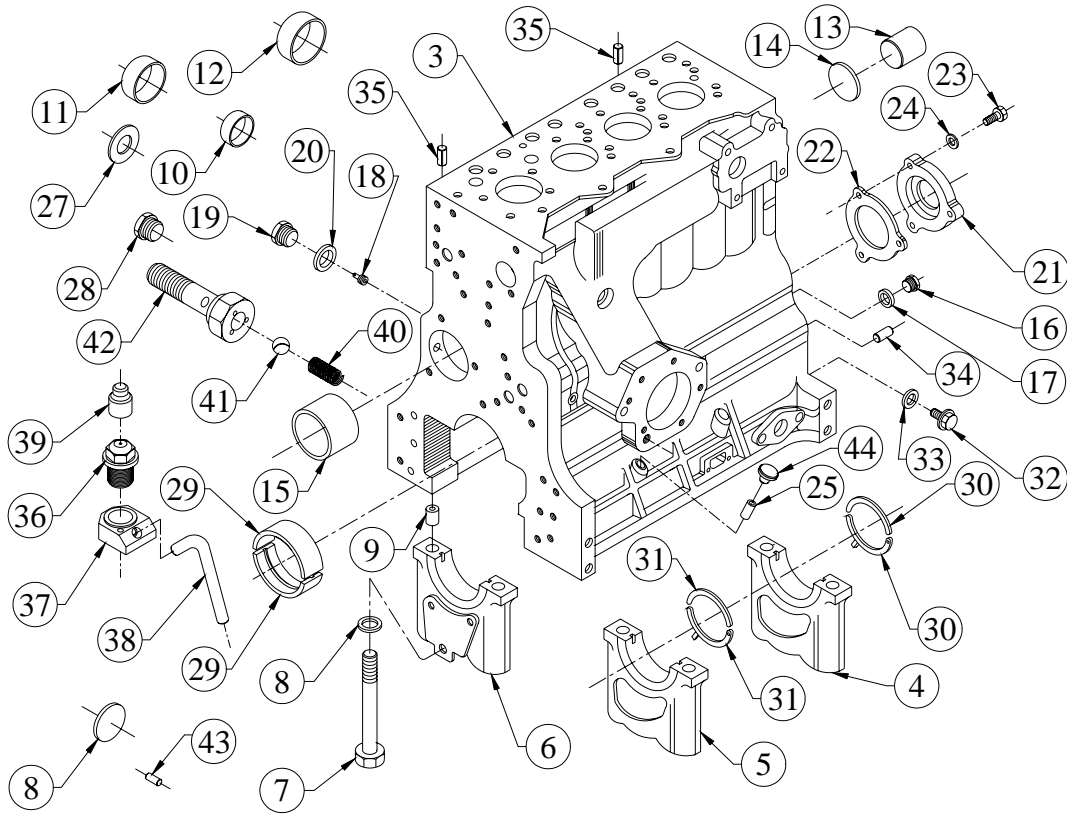

SR.NO.	PART NO.	DESCRIPTION	QTY.	REMARKS
*26	34.001.09.0.00	PLUG FOR OIL GALLERY	1	NOT ILLUSTRATED
27	50.565.10.000.	INTERNAL RUBBER LIP SEALING WASHER -M10- FOR FUEL LINES	1	
28	50.610.10.000.	CORE PLUG	1	
29	02.001.07.0.00	MAIN BRG TOP & BOTTOM (BEARING PART NO. * M-74400003)	5	
30	03.001.18.0.00	THRUST RING PAIR-DRIVE END, 102 DIA.)	1	
31	B2.005.22.0.00	THRUST RING PAIR-G.E.	1	
32	50.602.14.000.	PLUG (M14X1.5)	1	
33	50.565.14.000.	INTERNAL RUBBER LIP SEALING WASHER -M14- FOR FUEL LINES	1	
34	50.401.08.014.	DOWEL	2	
35	50.540.09.016.	SPRING DOWEL PIN	2	
36	4H.156.10.0.00	OIL SPRAY NOZZLE ASSLY.	4	
37	4H.156.02.0.00	NOZZLE BODY	1	
38	4H.156.03.0.00	PIPE FOR NOZZLE	1	
39	4H.156.04.0.00	BUTTON FOR OIL SPRAY NOZZLE	1	

TITLE: - MONOBLOCK CRANKCASE
(4RT - EXPORT)

GROUP: - 4H.156...EXP

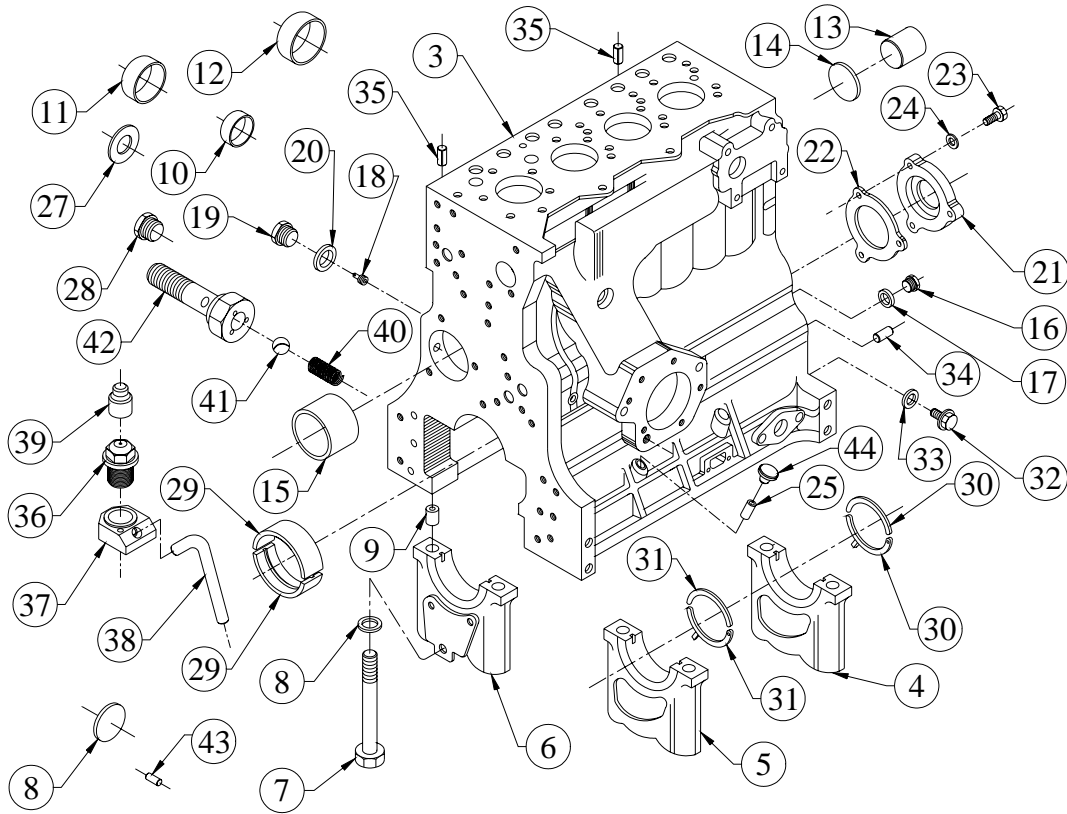

SR.NO.	PART NO.	DESCRIPTION	QTY.	REMARKS
40	02.002.02.0.00	SPRING	1	
41	02.002.04.0.00	STEEL BALL	1	
42	4H.156.07.0.00	SUB. ASSEMBLY OF SPECIAL BANJO BOLT (FOR OIL SPRAY NOZZLE.)	4	
43	50.401.04.012.	DOWEL PINS	4	
44	48.288.02.0.00	PLUG FOR DIP STICK HOLE	1	
*45	M-074400003	MAIN BEARING SET	1	(5 PAIRS) STD
*46	M-074400013	MAIN BEARING SET	1	0.25 mm U/S
*47	M-074400023	MAIN BEARING SET	1	0.50 mm U/S
*48	M-074400033	MAIN BEARING SET	1	0.75 mm U/S
*49	M-074400043	MAIN BEARING SET	1	1.00 mm U/S
*50	M-074400053	MAIN BEARING SET	1	1.25 mm U/S
*51	M-074400063	MAIN BEARING SET	1	1.50 mm U/S
*52	W-074500003	THRUST WASHER SET	1	CONSISTS 2 HALF RINGS FLYWHEEL END AND GEAR END

TITLE:- OIL FILLING BODY

GROUP:- 4H.027...EXP

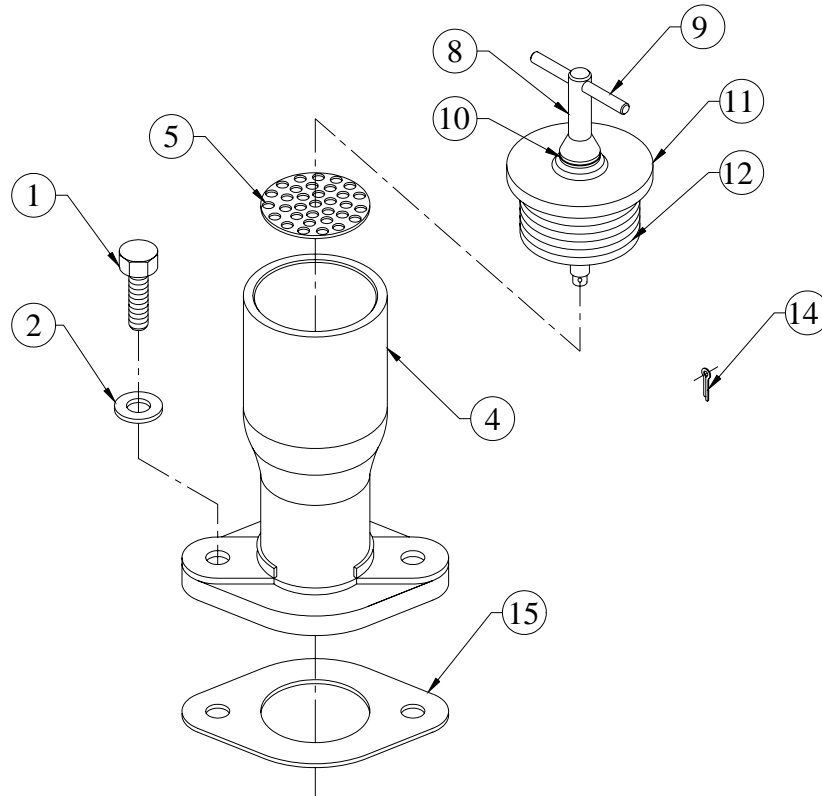

SR.NO.	PART NO.	DESCRIPTION	QTY.	REMARKS
1	50.003.08.025	SET SCREW - M8X1.25X25 - 8.8	2	
2	50.506.08.000.	PLAIN MACHINED WASHER - M8	2	
*3	4H.027.20.0.00	ASSEMBLY OF OIL FILLING BODY WITH JOINT	1	CONSISTING OF SR. NO.- 4 TO 6, 15
4	4H.027.01.0.00	OIL FILLING BODY	1	
5	34.036.50.0.00	PERFORATED DISC.	1	
*6	34.036.60.0.00	CAP ASSLY	1	CONSISTING OF SR. NO.- 7, 10 TO 14
*7	03.592.10.0.00	SUB-ASSLY.OF CLAMPING SCREW	1	CONSISTING OF SR. NO.- 8 & 9
8	03.592.01.0.00	CLAMPING SCREW FOR CAP	1	
9	34.036.16.0.00	PIN	1	
10	34.036.17.0.00	WASHER	1	
11	34.036.14.0.00	CAP	1	
12	03.592.02.0.00	RUBBER BUSH FOR CAP	1	

TITLE:- OIL FILLING BODY

GROUP:- 4H.027...EXP

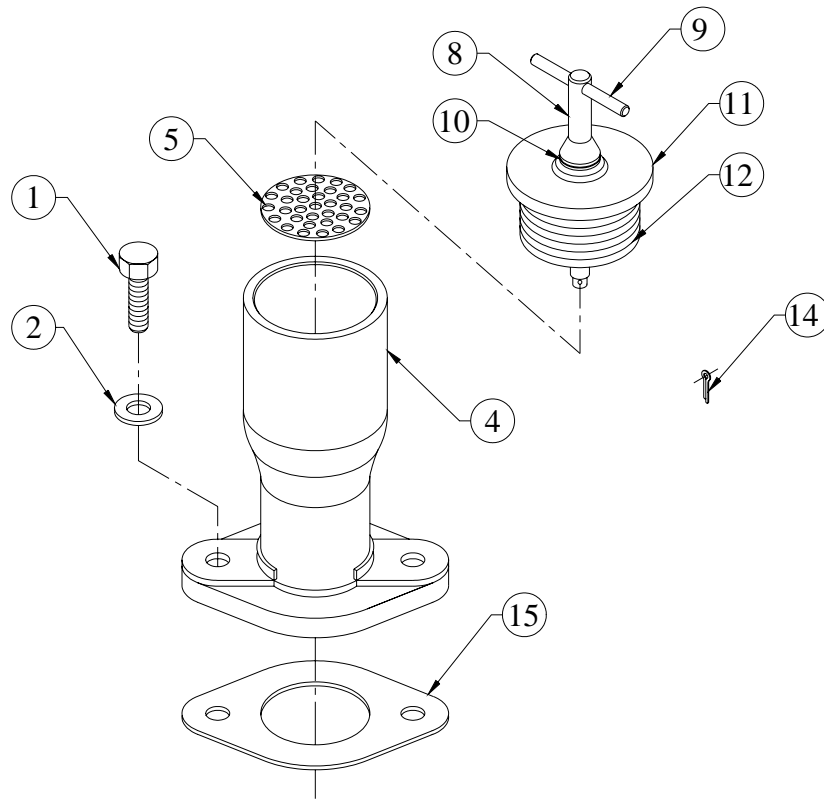

SR.NO.	PART NO.	DESCRIPTION	QTY.	REMARKS
*13	03.592.03.0.00	BOTTOM PLATE FOR CAP	1	NOT ILLUSTRATED
14	50.036.03.001	SPLIT COTTER PIN - 1/16"X1/2"	1	
15	4H.027.11.0.00	JOINT FOR OIL FILLING BODY	1	

TITLE:- OIL SEAL HOUSING (PG)

GROUP:- 2H.039...EXP

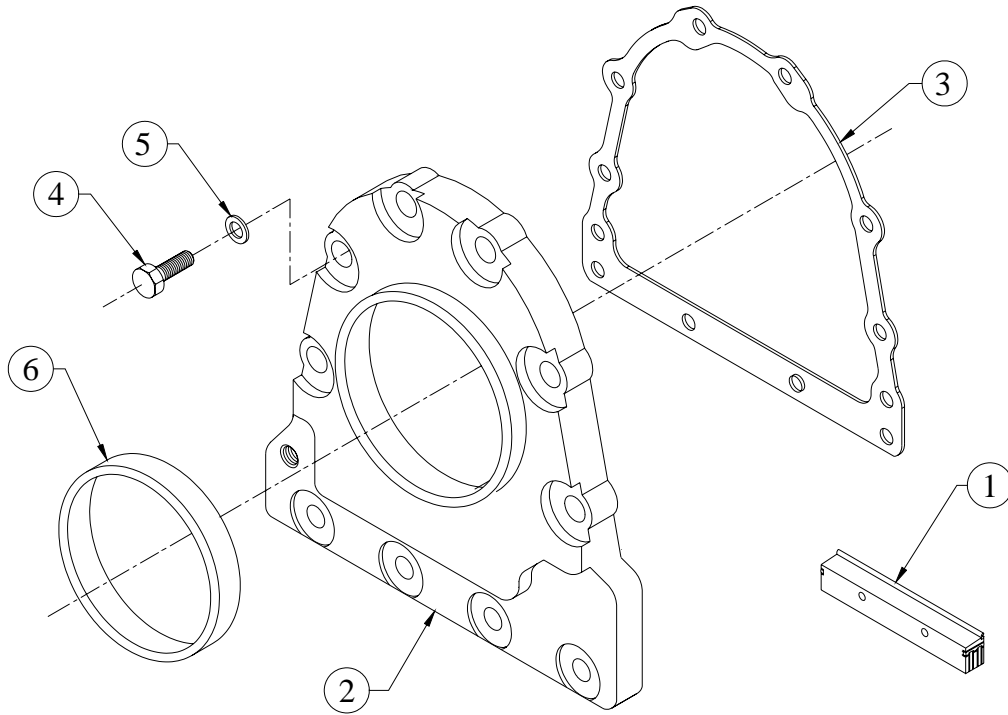

SR.NO.	PART NO.	DESCRIPTION	QTY.	REMARKS
1	2H.039.10.0.00	PLATE WITH RUBBER MOULDING (FOR FWE OIL SEAL HSG.)	1	
2	2H.006.01.0.00	OIL SEAL HSG.(F.W.E.)	1	
3	2H.006.11.0.00	JOINT FOR OIL SEAL HOUSING	1	
4	50.003.08.020	SET SCREW - M8X1.25X20 - 8.8	10	
5	50.506.08.000	PLAIN MACHINED WASHER - M8	10	
6	03.007.06.0.00	OIL SEAL (115X140 X16) CR MAKE	1	

TITLE:- OIL SUPPLY AND DRAIN ARRANGEMENT

GROUP:- 4H.222...EXP

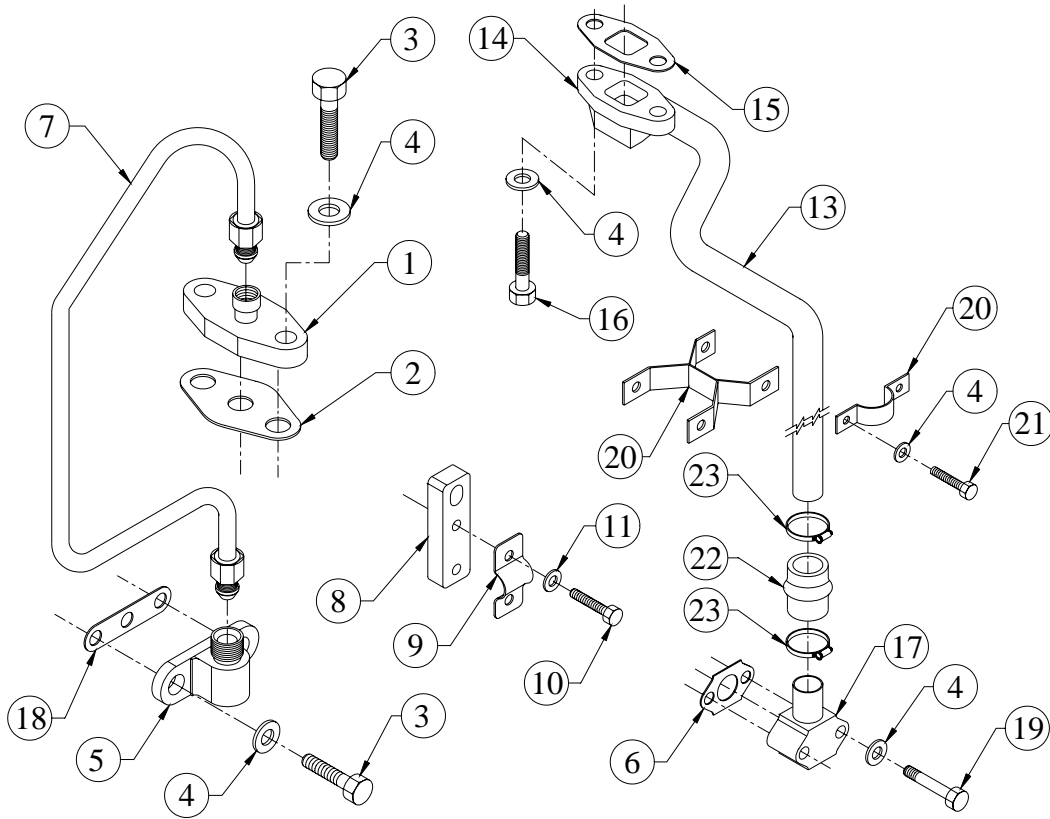

SR.NO.	PART NO.	DESCRIPTION	QTY.	REMARKS
1	4H.132.02.0.00	ADAPTOR (TURBOCHARGER SIDE)	1	
2	4H.132.27.0.00	JOINT FOR ADAPTOR (TURBO SIDE)	1	
3	50.003.08.025.	SET SCREW - M8X1.25X25 - 8.8	5	
4	50.506.08.000.	PLAIN MACHINED WASHER - M8	11	
5	4H.132.04.0.00	ADAPTOR (CRANKCASE SIDE)	1	
6	4H.132.31.0.00	JOINT FOR ADAPTOR CRANKCASE SIDE	1	
7	4H.222.01.0.00	LUB OIL INLET PIPE	1	
8	4H.132.06.0.00	CLAMPING PLATE	1	
9	4H.132.07.0.00	CLAMP	1	
10	50.003.06.012.	SET SCREW - M6X1X12 - 8.8	2	
11	50.506.06.000.	PLAIN MACHINED WASHER - M6	2	
*12	4H.222.03.0.00	LUB OIL DRAIN PIPE (K24 TURBO)	1	CONSISTING OF SR NO. 13 & 14
13	4H.222.02.0.00	LUB OIL DRAIN PIPE	1	
14	4H.132.22.0.00	FLANGE FOR TURBO DRAIN PIPE	1	

TITLE:- OIL SUPPLY AND DRAIN ARRANGEMENT

GROUP:- 4H.222...EXP

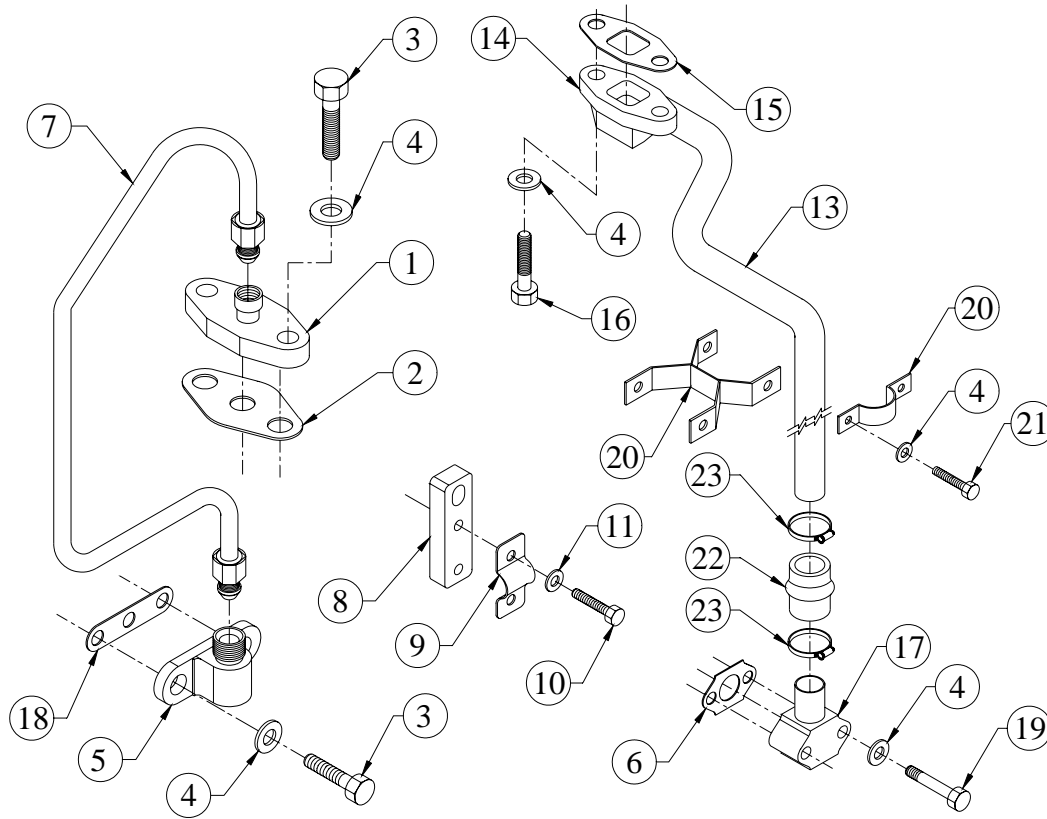

SR.NO.	PART NO.	DESCRIPTION	QTY.	REMARKS
15	4H.132.29.0.00	JOINT FOR LUB OIL DRAIN PIPE	1	
16	50.003.08.020.	SET SCREW - M8X1.25X20 - 8.8	2	
17	4H.132.13.0.00	ADAPTOR ASSEMBLY FOR TURBO DRAIN (CRANKCASE SIDE)	1	
18	4H.132.28.0.00	JOINT FOR ADAPTOR (CRANKCASE SIDE)	1	
19	50.002.08.045.	SET BOLT - M8X1.25X45 - 8.8	2	
20	4H.132.18.0.00	ASSEMBLY OF CLAMP STRAP	1	
21	50.003.08.010.	SET SCREW - M8X1.25X10 - 8.8	2	
22	4H.366.07.0.00	HOSE (FOR TURBO DRAIN PIPE)	1	
23	50.519.07.000.	WORM DRIVE HOSE CLIP (35 MM)	2	

TITLE :- PISTON & CONNECTING ROD
(TURBO P.G.- 40 DIA. PIN)

GROUP :- 4H.180

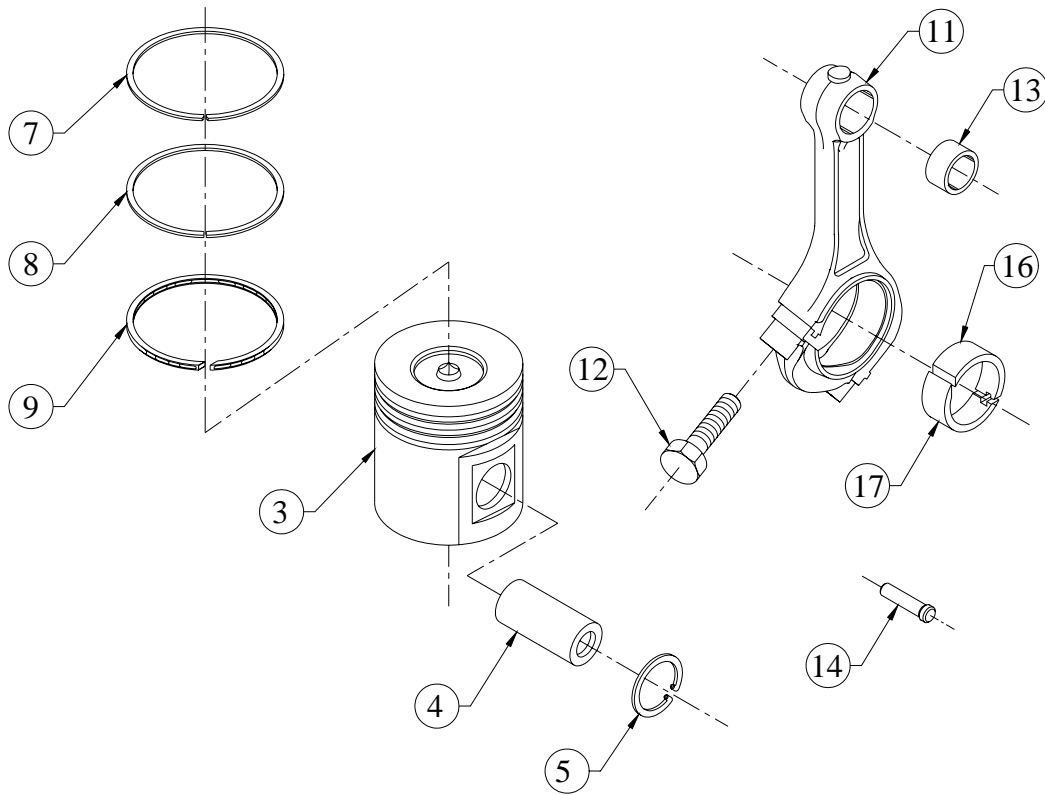

SR.NO.	PART NO.	DESCRIPTION	QTY.	REMARKS
*1	4H.180.40.0.00	PISTON & CON. ROD ASSLY.	1	CONSISTING OF SR. NO.- 2, 10 AND 15
*2	4H.180.10.0.00	PISTON ASSEMBLY COMPLETE	1	CONSISTING OF SR. NO.- 3 TO 6
3	4H.180.01.0.00	PISTON - SUITABLE FOR 40 MM DIA.PIN	1	
4	4H.180.05.0.00	PISTON PIN - 40 MM DIA.	1	
5	50.502.40.000.	CIRCLIP INTERNAL - 40 MM	2	
*6	2H.009.30.0.00	PISTON RING SET (105 DIA.)	1	CONSISTING OF SR. NO.- 7 TO 9
7	2H.009.02.0.00	TOP RING (105 DIA)	1	
8	2H.009.03.0.00	COMPRESSION RING (105 DIA)	1	
9	2H.009.04.0.00	OIL CONTROL RING (105 DIA)	1	
*10	4H.182.10.0.00	CON ROD ASSLY.	1	CONSISTING OF SR. NO.- 11 TO 14

**TITLE :- PISTON & CONNECTING ROD
(TURBO P.G.- 40 DIA. PIN)**

GROUP :- 4H.180

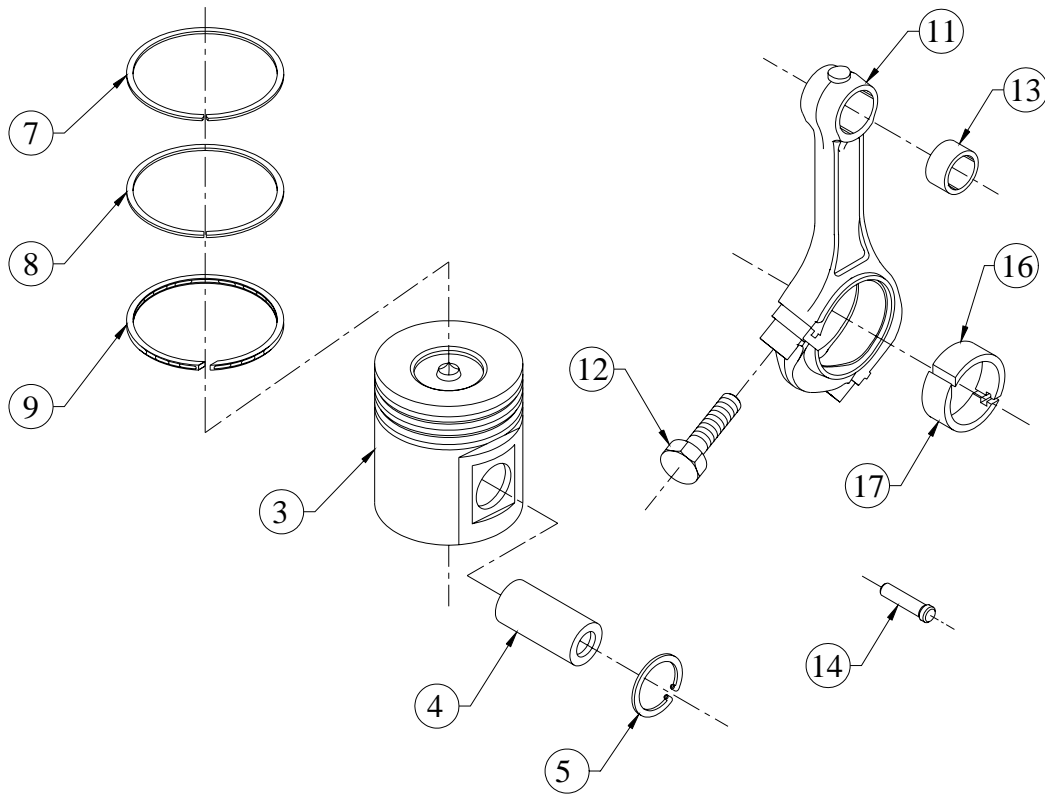

SR.NO.	PART NO.	DESCRIPTION	QTY.	REMARKS
11	4H.182.01.0.00	CON ROD (40 DIA PIN)	1	
12	02.021.08.0.00	CON ROD BOLT (FOR MASS BAL CON ROD)	2	
13	4H.182.02.0.00	SMALL END BUSH (40 DIA)	1	
14	4H.182.03.0.00	LOCATING PIN (FOR CON. ROD)	1	
*15	6H.015.03.0.00	LARGE END BEARING PAIR BEARING PART NO. *B - 075400003)	1	CONSIST OF SR. NO.16, 17
16	6H.015.04.0.00	CON ROD L.E.BEARING (TOP HALF)	1	
17	6H.015.05.0.00	CON ROD L.E.BEARING (BOTTOM HALF)	1	
*20	B-075400003	L.E. BEARING SET	1	(6 PAIRS) STD.
*21	B-075400013	L.E. BEARING SET	1	0.25 mm U/S
*22	B-075400023	L.E. BEARING SET	1	0.50 mm U/S
*23	B-075400033	L.E. BEARING SET	1	0.75 mm U/S
*24	B-075400043	L.E. BEARING SET	1	1.00 mm U/S
*25	B-075400053	L.E. BEARING SET	1	1.25 mm U/S
*26	B-075400063	L.E. BEARING SET	1	1.50 mm U/S

TITLE:- PUSHROD & TAPPETS

GROUP:- 2H.007

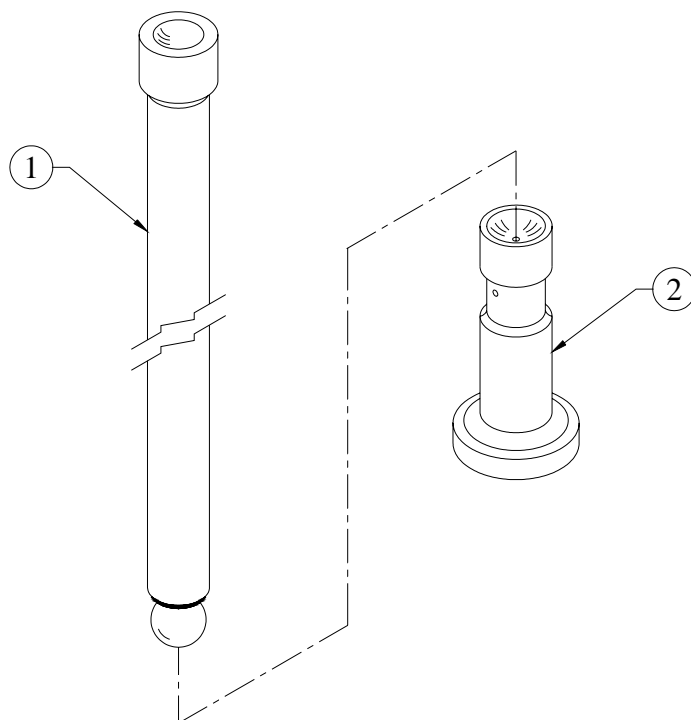

SR.NO.	PART NO.	DESCRIPTION	QTY.	REMARKS
1	02.024.70.0.00	PUSH ROD (WELDED)	2	
2	02.024.01.0.00	VALVE TAPPET	2	

**TITLE: -RADIATOR 4R1040TA CANOPY GENSET
W/O STONE GUARD (WITH 21 " FAN)**

GROUP: - 4H.762.1

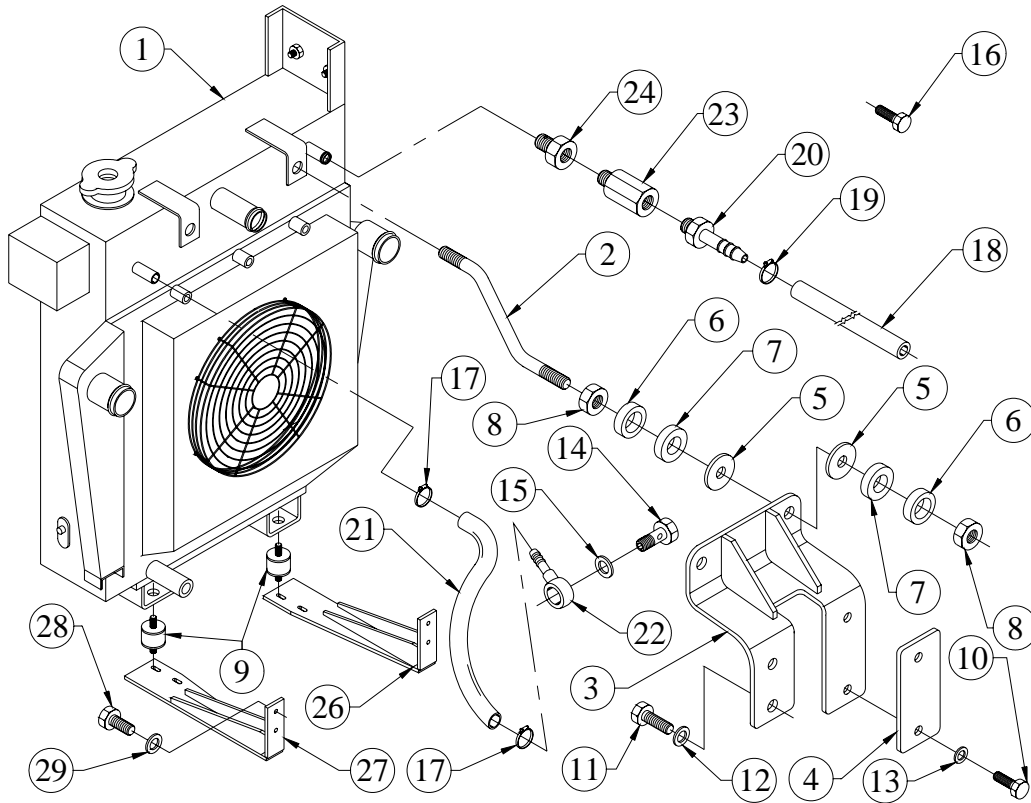

SR.NO.	PART NO.	DESCRIPTION	QTY.	REMARKS
1	4H.762.10.0.00	RADIATOR FOR 4R1040TA CANOPY GENSET W/O STONE GUARD	1	
2	4H.225.02.0.00	STAY FOR RADIATOR	2	
3	4H.225.01.0.00	BRACKET FOR RADIATOR STAY	1	
4	4H.225.06.0.00	SPACER FOR BRACKET	1	
5	6H.019.08.0.00	SPECIAL WASHER	8	
6	6H.019.07.0.00	BUSH	8	
7	6H.019.06.0.00	RUBBER BUSH	8	
8	50.006.12.000	NUT - M12X1.75 - GR.8	8	
9	48.213.08.0.00	ANTIVIBRATION MTG.- BOTTOM, RADIATOR.	2	
10	50.003.08.025	SET SCREW - M8X1.25X25 - 8.8	2	
11	50.003.10.030	SET SCREW - M10X1.5X30 - 8.8	2	
12	50.506.10.000	PLAIN MACHINED WASHER - M10	2	
13	50.506.08.000	PLAIN MACHINED WASHER - M8	6	
14	50.504.04.000	BANJO BOLT - M14X1.5	2	

**TITLE: -RADIATOR 4RTA CANOPY GENSET
W/O STONE GUARD (WITH 21 " FAN)**

GROUP: - 4H.762.1

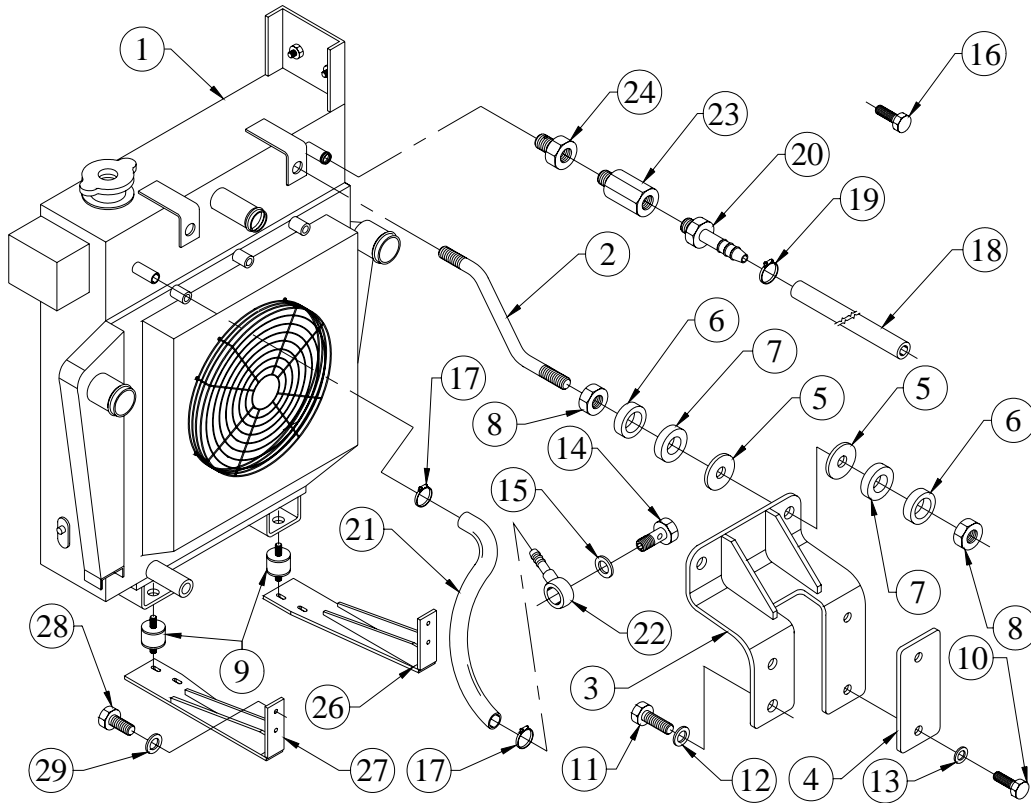

SR.NO.	PART NO.	DESCRIPTION	QTY.	REMARKS
15	50.565.14.000	INTERNAL RUBBER LIP SEALING WASHER -M14- FOR FUEL LINES	5	
16	50.003.08.020	SET SCREW - M8X1.25X20 - 8.8	2	
17	50.519.07.000	WORM DRIVE HOSE CLIP (35 MM)	2	
18	4H.225.09.0.00	VENT PIPE	1	
19	50.519.03.000	WORM DRIVE HOSE CLIP (22 MM)	2	
20	4H.225.11.0.00	ADAPTOR FOR VENT PIPE	1	
21	4H.225.12.0.00	HOSE (MAKE UP WATER LINE)	1	
22	06.610.10.0.00	SUB ASSLY OF HOSE TAIL (M14 BANJO)	1	
23	4H.225.13.0.00	SPACER FOR VENT CONNECTION	1	
24	4H.225.14.0.00	ADAPTOR FOR WATER TEMP. SWITCH	1	
*25	4H.762.20.0.00	ASSEMBLY OF RADIATOR SUPPORT FOR 4R1040T/4R1040TA ENGINE	1	CONSISTING OF SR. NO.- 26 TO 29
26	4H.762.50.0.PR	RADIATOR SUPPORT FOR 4R1040TA ENGINE (RH FROM FWE)	1	

**TITLE: -RADIATOR 4RTA CANOPY GENSET
W/O STONE GUARD (WITH 21 " FAN)**

GROUP: - 4H.762.1

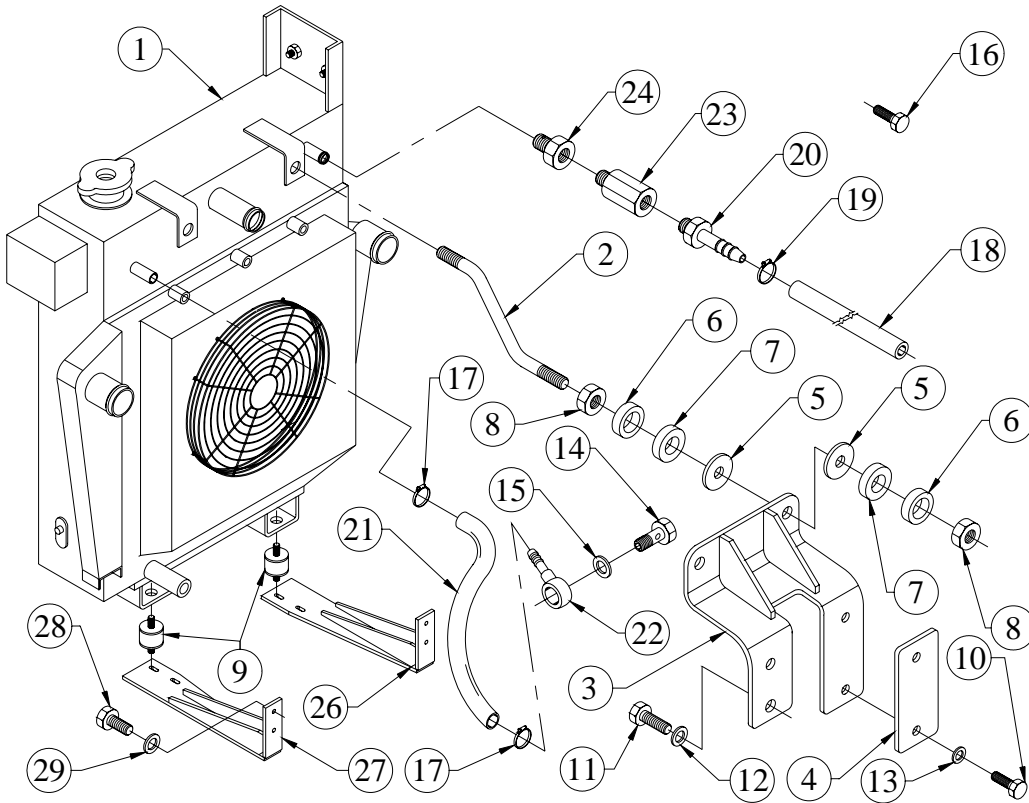

SR.NO.	PART NO.	DESCRIPTION	QTY.	REMARKS
27	4H.762.51.0.PR	RADIATOR SUPPORT FOR 4R1040TA ENGINE (LH FROM FWE)	1	
28	50.003.10.020	SET SCREW - M10X1.5X20 - 8.8	4	
29	65.061.15.0.00	HARD WASHER	4	

TITLE:- RADIATOR FAN
(21" METTALIC PUSHER)

GROUP:- 6H.330

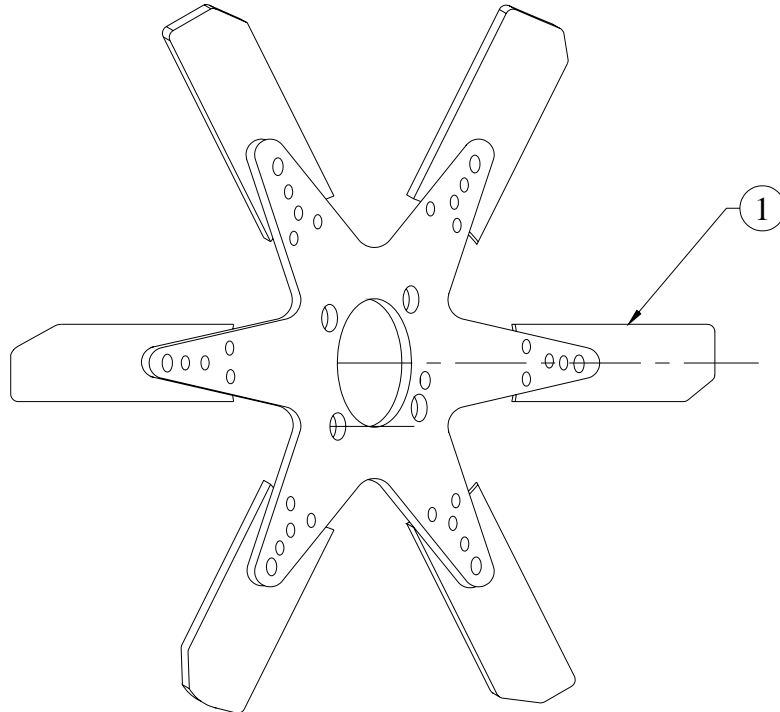

SR.NO.	PART NO.	DESCRIPTION	QTY.	REMARKS
1	6H.330.01.0.00	FAN (PUSHER TYPE - METTALLIC 21" DIA MTG. HOLE 55 PCD)	1	

**TITLE :- RADIATOR FAN MOUNTING
(STAGE 1, PG)**

GROUP :- 4H.083.1

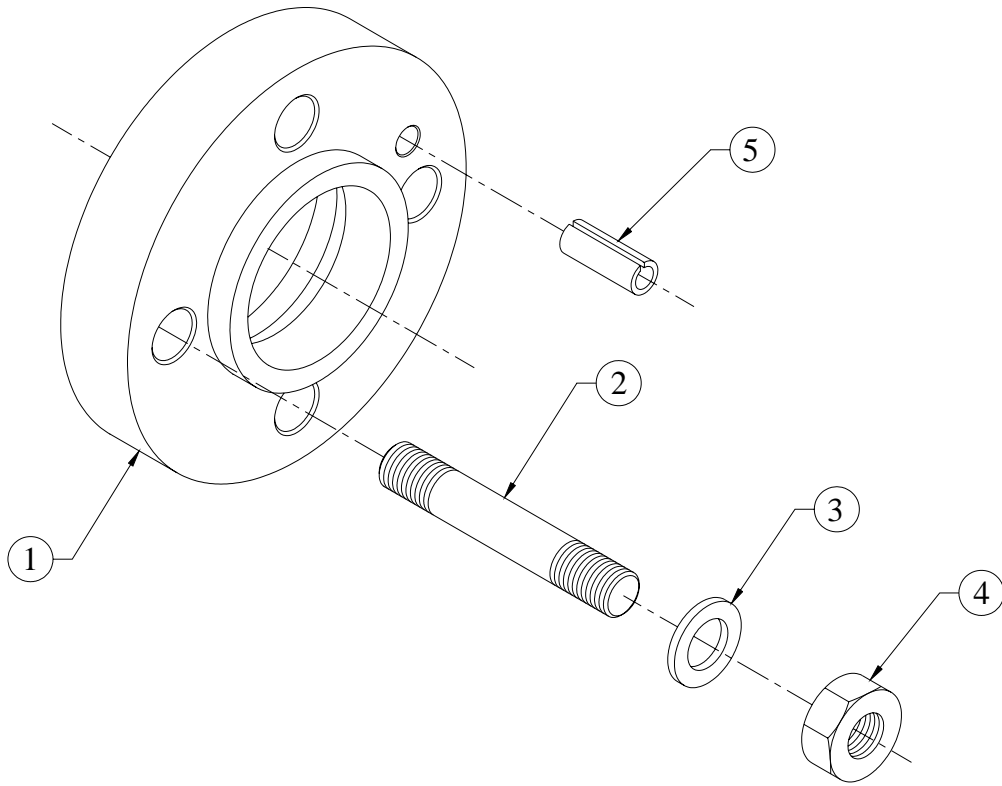

SR.NO.	PART NO.	DESCRIPTION	QTY.	REMARKS
1	40.054.03.0.00	SPACER FOR FAN (15MM)	1	
2	50.010.08.040	STUD M8X1.25X40 – 8.8	4	
3	50.506.08.000	PLAIN MACHINED WASHER – M8	4	
4	50.006.08.000	NUT M8X1.25 – GR. 8	4	
5	50.540.09.016	SPRING DOWEL PIN	1	

TITLE:- ROCKER COVER (EXPORT - USA)

GROUP:-4H.160...EXP.

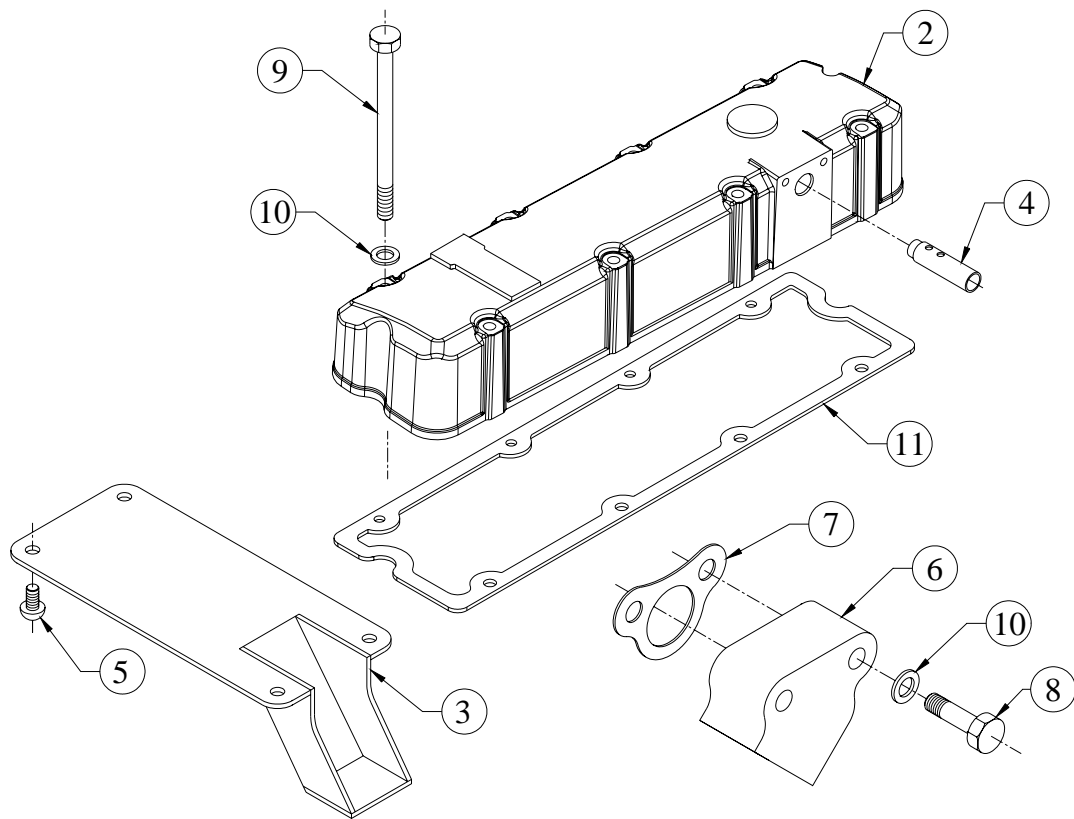

SR.NO.	PART NO.	DESCRIPTION	QTY.	REMARKS
*1	4H.160.20.0.00	SUB ASSLY. OF ROCKER COVER AND BREATHER PIPE	1	CONSISTING OF SR. NO.- 2 TO 8
2	4H.160.01.0.00	ROCKER COVER (TURBO ENGINE)	1	
3	4H.160.02.0.00	DEFLECTOR PLATE	1	
4	4H.160.03.0.00	BREATHER PIPE	1	
5	10.046.02.0.00	P K DRIVE SCREW 1/8"X3/8" (RIVET)	4	
6	4H.161.03.0.00	ADAPTOR FOR BREATHER PIPE	1	
7	4H.161.11.0.00	JOINT FOR BREATHER PIPE	1	
8	50.002.08.045	SET BOLT - M8X1.25X45 - 8.8	2	
9	50.002.08.100	SET BOLT - M8X1.25X100 - 8.8	8	
10	50.506.08.000	PLAIN MACHINED WASHER - M8	8	
11	4H.009.11.0.00	JOINT FOR ROCKER COVER	1	

TITLE:- SPIN ON FUEL FILTER
(MICO NO F002 H20 116)

GROUP:- 3H.132

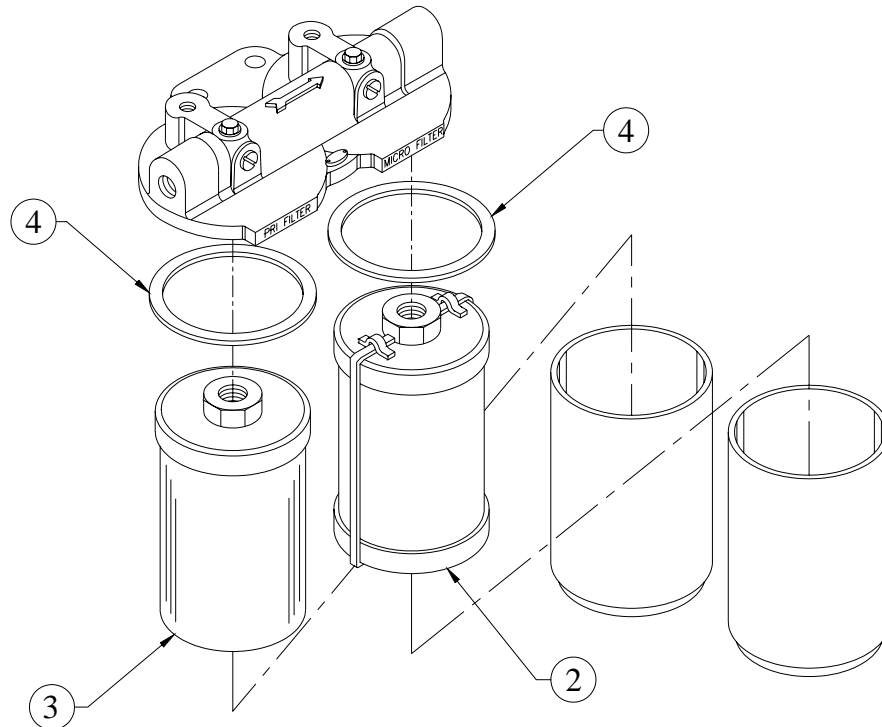

SR.NO.	PART NO.	DESCRIPTION	QTY.	REMARKS
*1	3H.132.10.0.00	SPIN ON FUEL FILTER (TWIN BOWL, 0.6 LIT.)	1	CONSISTING OF SR. NO. 2 TO 4
2	3H.132.01.0.00	PRIMARY ELEMENT	1	
3	3H.132.02.0.00	SECONDARY ELEMENT	1	
4	3H.132.03.0.00	SEALING RING (FUEL FILTER)	2	

**TITLE:- STOP SOLENOID ASSEMBLY 12 VDC
FOR MICO PUMP ENRGIES
TO RUN WITHOUT TIMER**

GROUP:- 3H.135.1

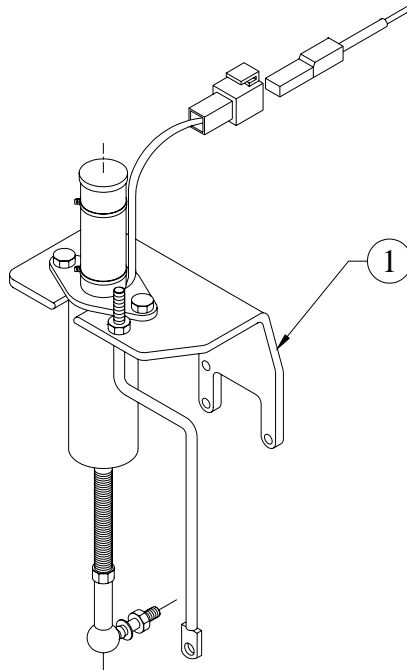

SR.NO.	PART NO.	DESCRIPTION	QTY.	REMARKS
1	3H.135.20.0.00	STOP SOLENOID ASSEMBLY 12V D.C. FOR MICO PUMP ENRGIES TO RUN WITHOUT TIMER	1	

**TITLE :- SUCTION TUBE
(TURBOCHARGED ENGINE)**

GROUP :- 4H.231

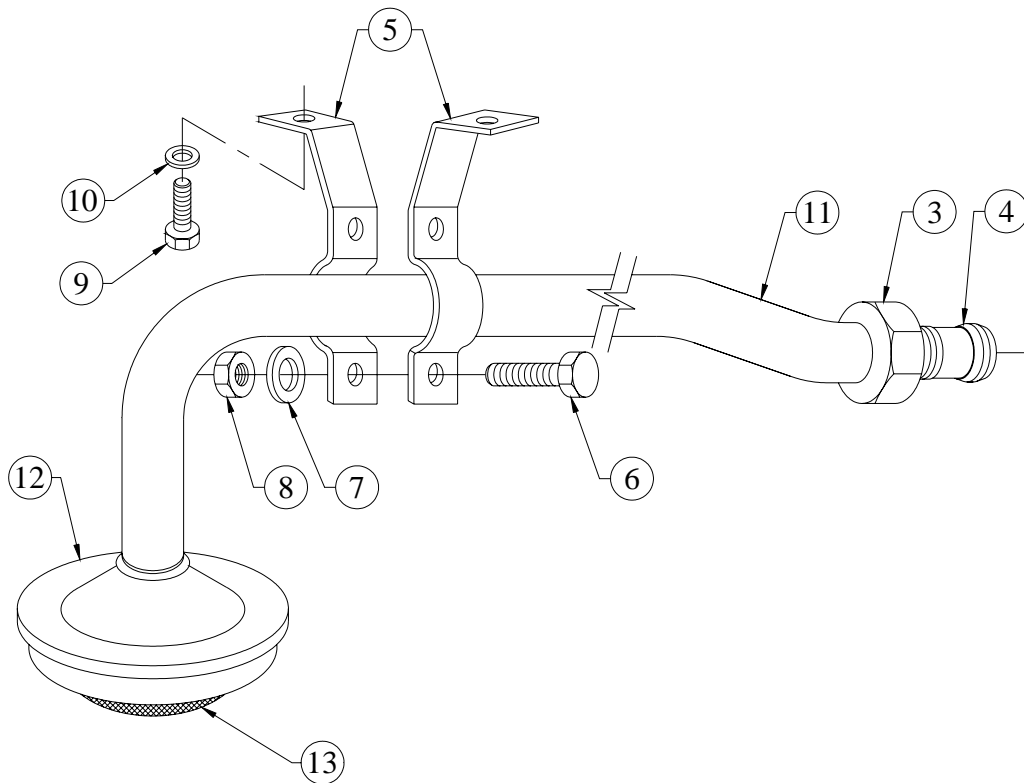

SR.NO.	PART NO.	DESCRIPTION	QTY.	REMARKS
*1	4H.231.20.0.00	SUCTION TUBE ASSLY.(TURBO ENGINE)	1	CONSISTING OF SR. NO. 2 TO 8
*2	4H.231.10.0.00	SUCTION TUBE SUB ASSLY.(TURBO ENGINE)	1	CONSISTING OF SR. NO. 11 TO 13
3	06.008.02.0.00	UNION NUT	1	
4	06.008.03.0.00	DOUBLE CONE RING	1	
5	06.008.04.0.00	CLAMPING STRAP	2	
6	50.003.06.012.	SET SCREW - M6X1X12 - 8.8	2	
7	50.506.06.000.	PLAIN MACHINED WASHER - M6	4	
8	50.006.06.000.	NUT - M6X1 - GR.8	2	
9	50.003.08.016.	SET SCREW - M8X1.25X16 - 8.8	2	
10	50.506.08.000.	PLAIN MACHINED WASHER - M8	2	
11	4H.231.01.0.00	SUCTION TUBE (TURBO CHRGED ENGINE)	1	
12	06.008.05.0.00	FUNNEL	1	
13	04.011.03.0.00	STRAINER BASKET	1	

TITLE:- THERMOSTAT AND HOUSING ASSEMBLY (USA)

GROUP:- 4H.096...EXP

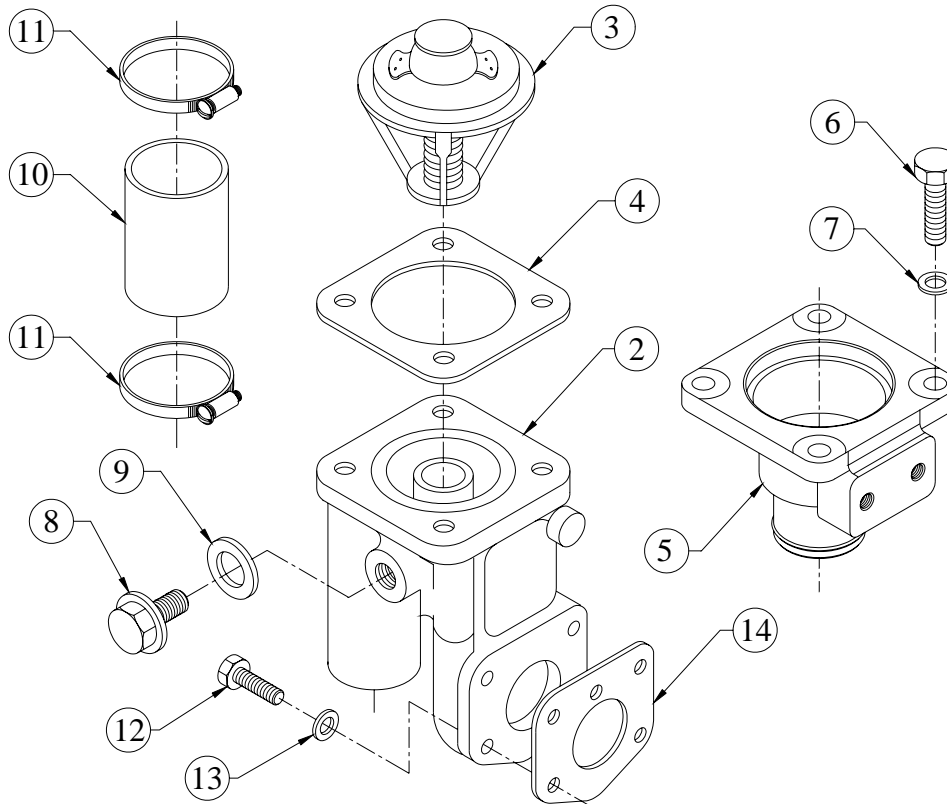

SR.NO.	PART NO.	DESCRIPTION	QTY.	REMARKS
*1	4H.096.20.0.00	THERMOSTAT AND HOUSING ASSEMBLY (NON ASBESTOS JOINT)	1	CONSISTING OF SR. NO. 3 TO 7 AND 10 TO 13
2	4H.053.01.0.00	THERMOSTAT HOUSING	1	
3	39.040.09.0.00	THERMOSTAT ELEMENT (74 DEG) - WTIL NO.DEV358	1	
4	4H.053.12.0.00	JOINT FOR THERMOSTAT COVER	1	
5	4H.096.03.0.00	THERMOSTAT COVER	1	
6	50.003.08.025	SET SCREW - M8X1.25X25 - 8.8	4	
7	50.506.08.000	PLAIN MACHINED WASHER - M8	4	
8	50.602.14.000	PLUG (M14X1.5)	1	
9	50.565.14.000	INTERNAL RUBBER LIP SEALING WASHER	1	
10	4H.023.02.0.00	BYPASS HOSE	1	
11	4H.405.07.0.00	STAINLESS STEEL HOSE CLIP S/F 35 TO 41 MM HOSE O.D (TO REPLACE 50519/08)	2	

**TITLE:- THERMOSTAT AND HOUSING
ASSEMBLY (USA)**

GROUP:- 4H.096...EXP

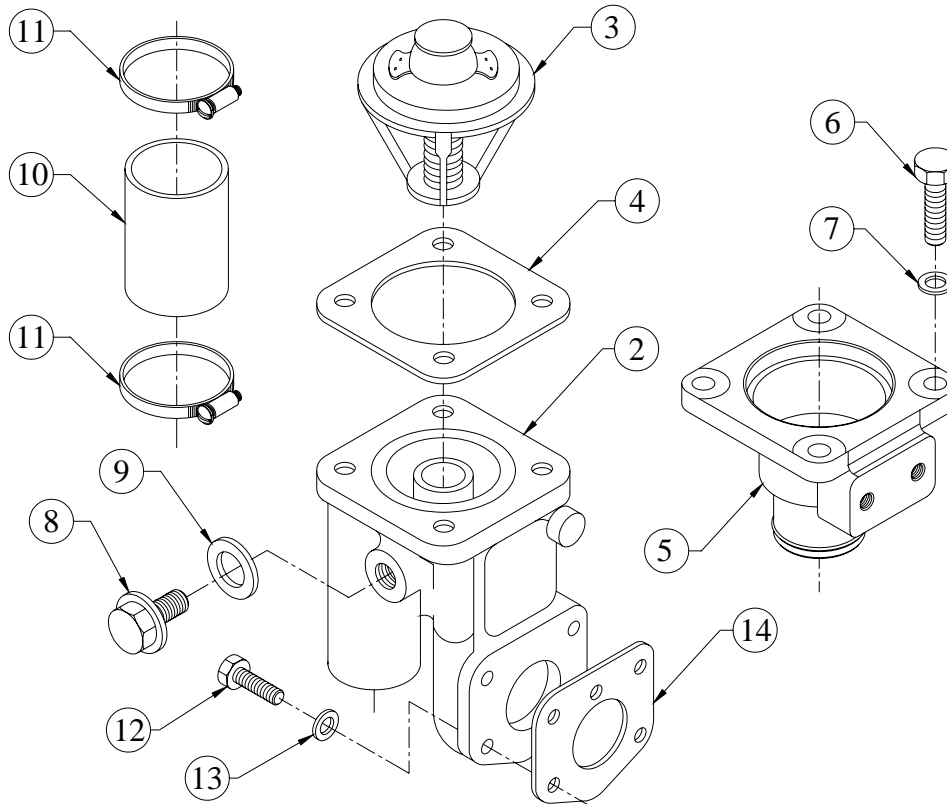

SR.NO.	PART NO.	DESCRIPTION	QTY.	REMARKS
12	50.003.08.025	SET SCREW - M8X1.25X25 - 8.8	4	
13	50.506.08.000	PLAIN MACHINED WASHER - M8	4	
14	4H.053.11.0.00	JOINT FOR THERMOSTAT HOUSING	1	

TITLE :- TURBOCHARGER FOR 4R1040TA ENGINE

GROUP :- 4H.277

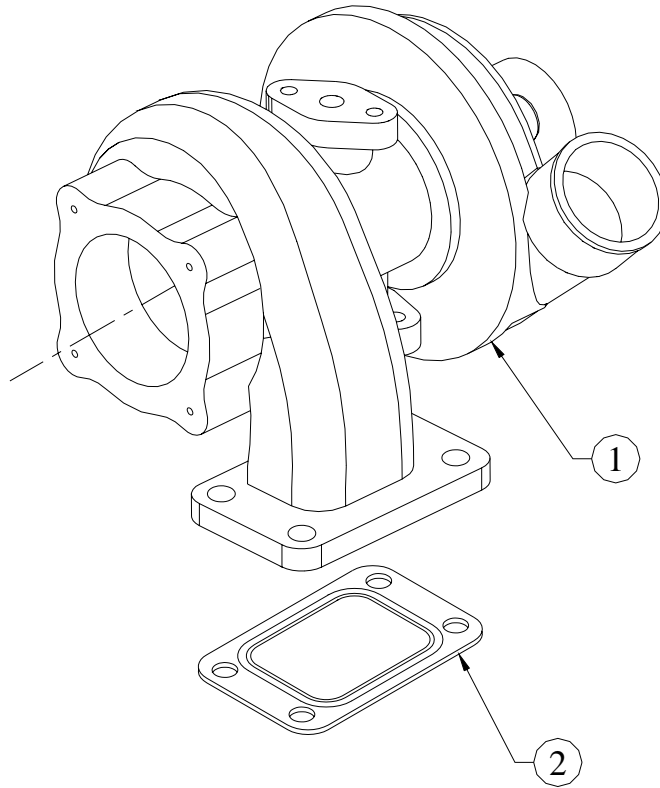

SR.NO.	PART NO.	DESCRIPTION	QTY.	REMARKS
1	4H.277.10.0.00	TURBOCHARGER (K24 --- 5.11) FOR 4R1040TA ENGINE	1	
2	6H.029.01.0.00	GASKET (FOR TURBOCHARGER)	1	

TITLE :- V BELT (XPA 1250)

GROUP :- 4H.069

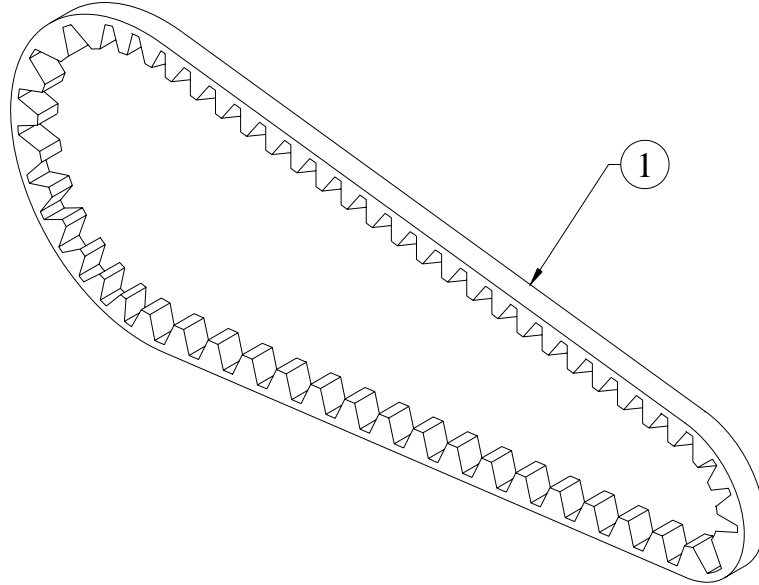

SR.NO.	PART NO.	DESCRIPTION	QTY.	REMARKS
1	4H.069.01.0.00	V BELT (XPA 1250) COGGED	1	

TITLE:- VALVE ROCKER ASSEMBLY.

GROUP:- 4H.008

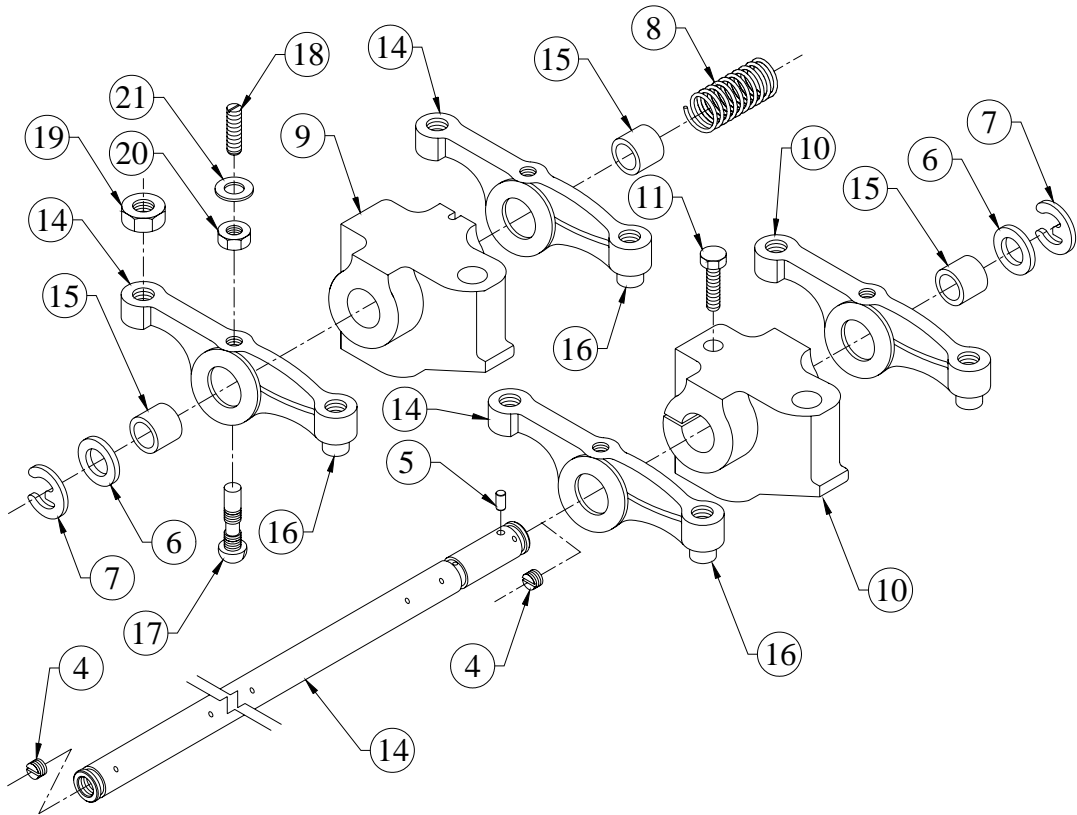

SR.NO.	PART NO.	DESCRIPTION	QTY.	REMARKS
*1	4H.008.10.0.00	VALVE ROCKER ASSEMBLY-COMplete.	1	CONSISTING OD SR. NO. 2, 6 TO 12
*2	4H.008.20.0.00	ROCKER SHAFT SUB.ASSEMBLY.	1	CONSISTING OD SR. NO. 3 TO 5
3	4H.008.01.0.00	ROCKER SHAFT (FINISH)	1	
4	50.022.12.010.	SOCKET HEAD GRUB SCREW - M12X10	2	
5	4H.008.04.0.00	GROOVED SOCKET PIN	1	
6	2H.022.04.0.00	WASHER (FOR ROCKER ARM)	2	
7	50.513.15.000.	E TYPE CIRCLIP-EXTERNAL (15 DIA.)	2	
8	2H.022.03.0.00	SPRING FOR ROCKER SHAFT.	3	
9	2H.022.01.0.00	ROCKER SUPPORT (FINISH) (FWE)	1	
10	2H.022.02.0.00	ROCKER SUPPORT (FINISH)	3	
11	50.003.08.030.	SET SCREW - M8X1.25X30 - 8.8	3	

TITLE:- VALVE ROCKER ASSEMBLY.

GROUP:- 4H.008

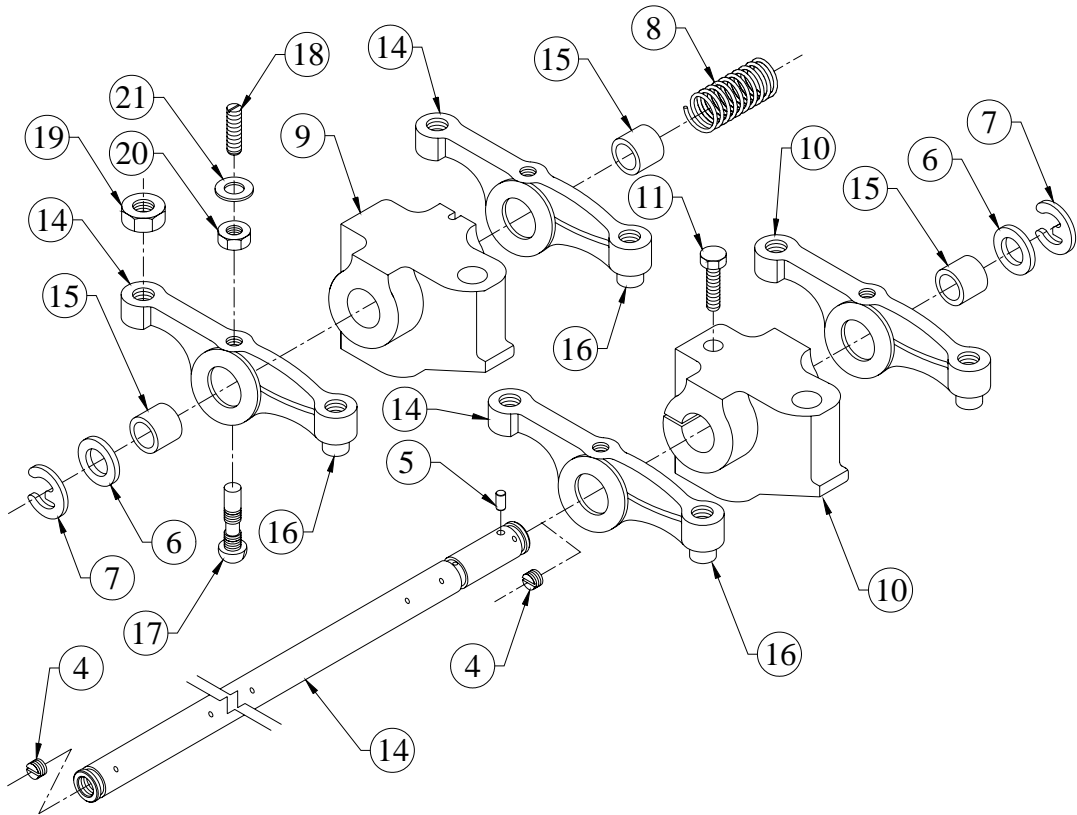

SR.NO.	PART NO.	DESCRIPTION	QTY.	REMARKS
*12	02.024.20.0.00	VALVE ROCKER ASSLY	8	CONSISTING OF SR. NO. 13, 16 TO 20
*13	02.024.23.0.00	ROCKER ARM SUB ASSEMBLY (WITH VR BUSH)	1	CONSISTING OF SR. NO. 14, 15
14	02.024.11.0.00	ROCKER ARM	1	
15	02.024.12.0.00	V.R. BUSH	1	
16	02.024.15.0.00	V.R.TOE	1	
17	02.024.13.0.00	ROCKER-ARM ADJ. SCREW	1	
18	02.024.14.0.00	OIL METERING SCREW	1	
19	50.006.06.000.	NUT - M6X1 – GR.8	1	
20	60.007.03.0.00	NUT	1	
21	F6.007.13.0.00	WASHER	6	

TITLE: - WATER INLET AND OUTLET CONNECTION FOR RADIATOR

GROUP: - 4H.226

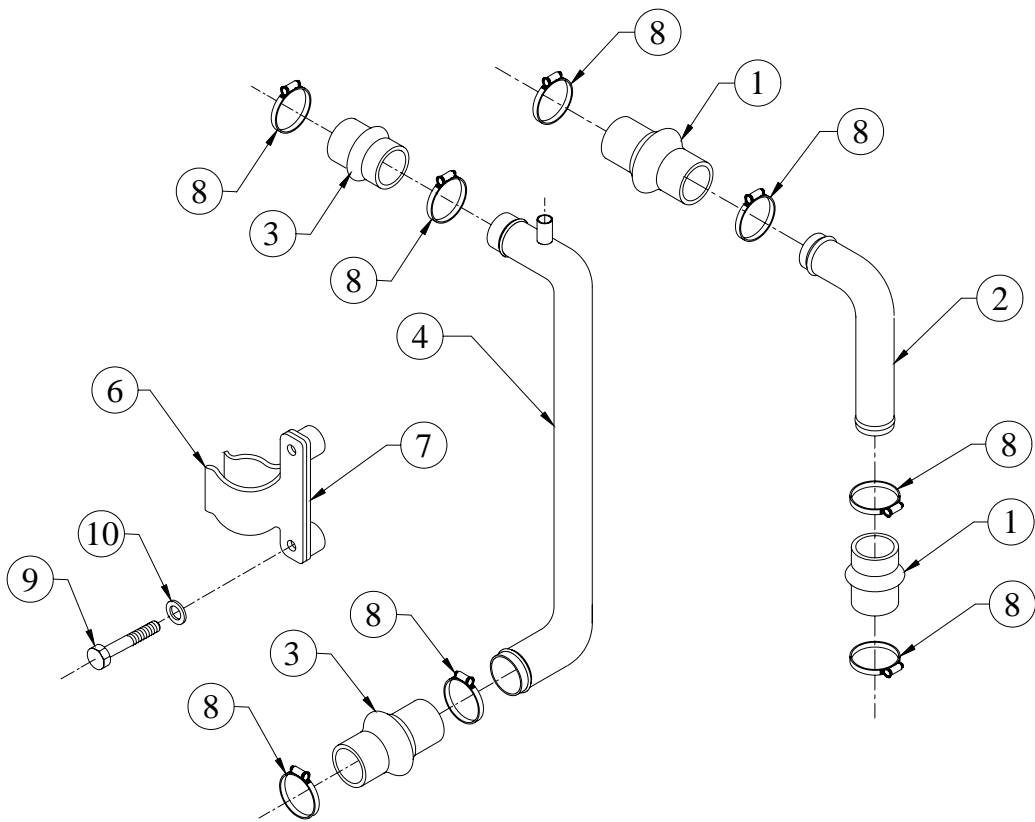

SR.NO.	PART NO.	DESCRIPTION	QTY.	REMARKS
1	4H.073.01.0.00	HOSE THERMOSTAT TO RADIATOR (45X45X110L)	2	
2	4H.226.02.0.00	PIPE (THERMOSTAT TO RADIATOR INLET)	1	
3	4H.073.02.0.00	HOSE WATER PUMP TO RADIATOR (45X45X80L)	2	
4	4H.226.01.0.00	PIPE (RADIATOR TO PUMP INLET)	1	
*5	4H.073.10.0.00	CLAMP ASSLY FOR PIPE	1	CONSISTING OF SR. NO.- 6 & 7
6	4H.073.04.0.00	UPPER CLAMP FOR PIPE	1	
7	4H.073.05.0.00	LOWER CLAMP FOR PIPE	1	
8	50.519.11.000.	WORM DRIVE HOSE CLIP (61 MM)	8	
9	50.002.08.075	SET BOLT - M8X1.25X75 - 8.8	2	
10	50.506.08.000	PLAIN MACHINED WASHER - M8	2	

TITLE: -WATER PUMP

GROUP: -4H.052...EXP

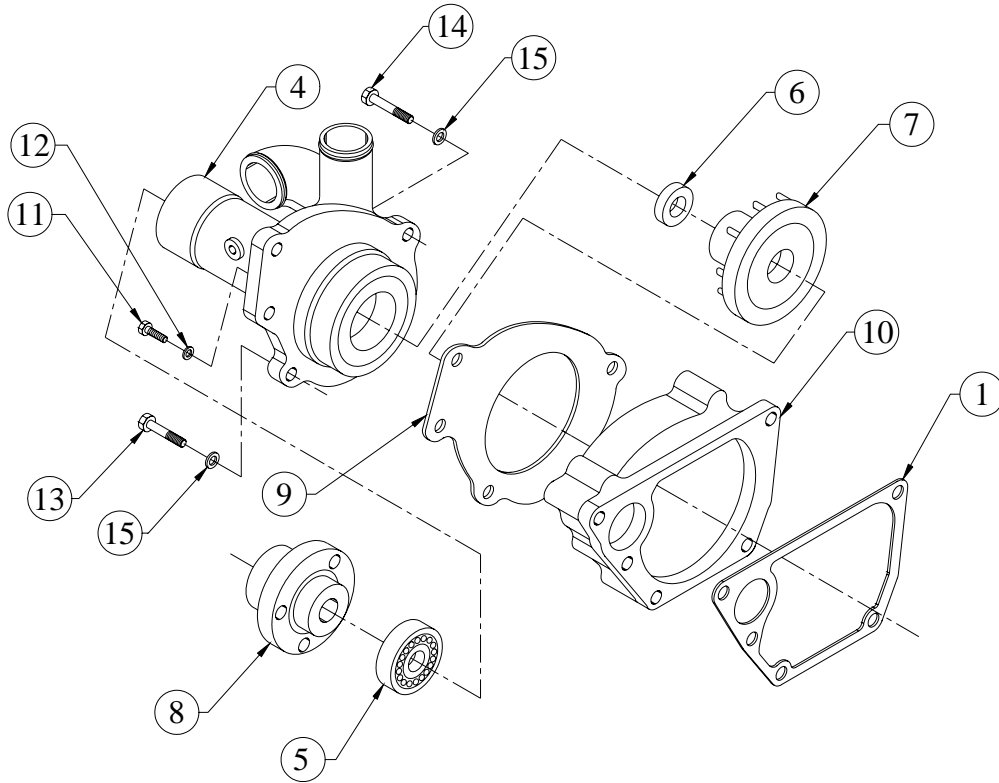

SR.NO.	PART NO.	DESCRIPTION	QTY.	REMARKS
1	4H.052.12.0.00	JOINT FOR DELIVERY VOLUTE	1	
*2	4H.052.95.0.00	WATER PUMP ASSEMBLY (HIGHER BEARING SIZE)	1	CONSISTING OF SR. NO.- 3, 10 TO 12
*3	4H.052.70.0.00	SUB ASSEMBLY OF DILEVERY VOLUTE	1	CONSISTING OF SR. NO.- 4 TO 9
4	4H.052.05.0.00	BEARING HOUSING (FOR 42 DIA SPINDLE BEARING)	1	
5	4H.052.06.0.00	SPINDLE BEARING (42 DIA)	1	
6	4H.052.07.0.00	UNITISED SEAL (KACO)	1	
7	4H.021.04.0.00	IMPELLER (95 DIA)	1	
8	4H.021.07.0.00	HUB FOR PUMP PULLEY	1	
9	4H.052.11.0.00	JOINT FOR BEARING HOUSING (282.5 CRS)	1	
10	4H.052.02.0.00	DELIVERY VOLUTE (282.5 CRS)	1	
11	50.003.08.025	SET SCREW - M8X1.25X25 - 8.8	3	
12	10.020.03.0.00	HARD WASHER (F)	3	
13	50.002.10.060	SET BOLT - M10X1.5X60 - 8.8	3	

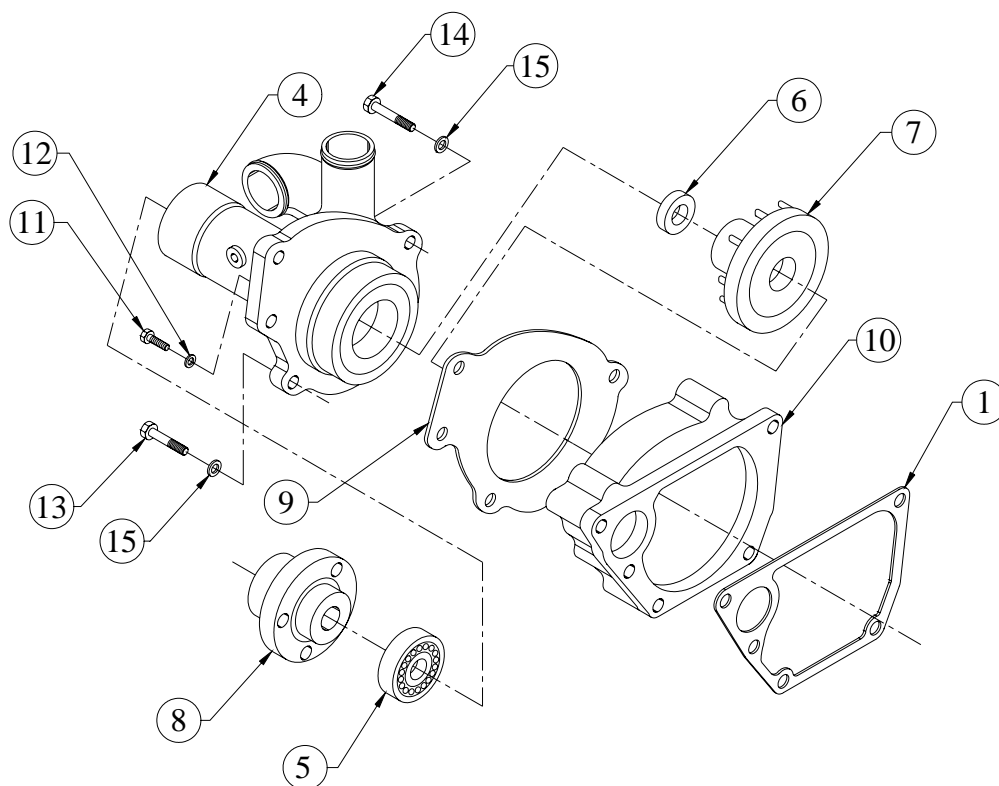
TITLE: -WATER PUMP**GROUP: -4H.052...EXP**

SR.NO.	PART NO.	DESCRIPTION	QTY.	REMARKS
14	50.002.10.070	SET BOLT - M10X1.5X70 - 8.8	2	
15	50.506.10.000	PLAIN MACHINED WASHER - M10	5	

TITLE:- WATER PUMP PULLEY (120 PCD,1,SPA)

GROUP:- 4H.005

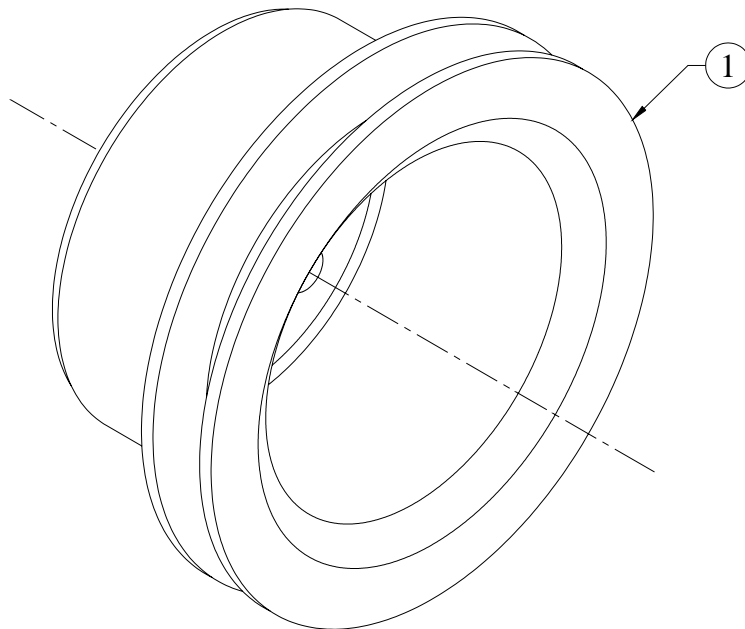

SR.NO.	PART NO.	DESCRIPTION	QTY.	REMARKS
1	4H.021.08.0.00	WATER PUMP PULLEY SPA SECTION (120 PCD)	1	

TITLE :- WATER TEMP.SW.(95 DEG.+1/- 3 DEG)

GROUP :- 46.260

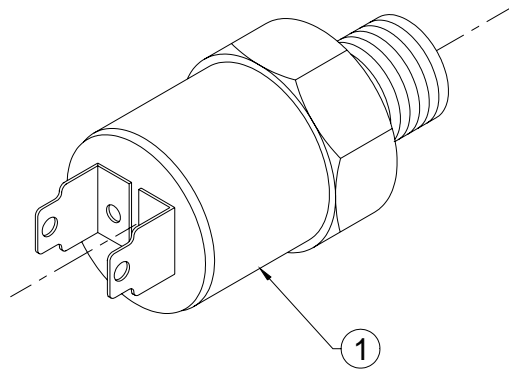

SR.NO.	PART NO.	DESCRIPTION	QTY.	REMARKS
1	46.260.01.0.00	WATER TEMP.SWITCH 95 +1/-3 DEG (YANKEE)	1	

**TITLE: -SET OF JOINTS, WASHERS,
'O' RINGS & HOSES (4H.2549)**

GROUP: -

SR.NO.	PART NO.	DESCRIPTION	QTY.	REMARKS
*1	4H.842.76.0.00	SET OF JOINTS	1	CONSISTING OF SR. NO.- 2 TO 30
*2	2H.005.11.0.00	JOINT FOR GEAR COVER	1	
*3	2H.006.11.0.00	JOINT FOR OIL SEAL HOUSING	1	
*4	2H.013.11.0.00	JOINT FOR DELIVERY BODY	1	
*5	2H.017.11.0.00	JOINT FOR COVER FOR FUEL PUMP GEAR	1	
*6	2H.037.11.0.00	JOINT FOR FRONT COVER	1	
*7	34.016.12.0.00	JOINT FOR FUEL PUMP (NON ASBESTOS)	1	
*8	34.107.06.0.00	JOINT FOR ADAPTOR ON EX.MANIFOLD	1	
*9	3H.007.13.0.00	JOINT FOR LUB OIL COOLER (NON ASBESTOS GASKET)	1	
*10	3H.007.15.0.00	JOINT FOR HEADER	1	
*11	4H.001.14.0.00	JOINT FOR CAM BORE BLANKING PLATE	1	

**TITLE: -SET OF JOINTS, WASHERS,
'O' RINGS & HOSES (4H.2549)**

GROUP: -

SR.NO.	PART NO.	DESCRIPTION	QTY.	REMARKS
*12	4H.007.24.0.00	GASKET FOR CYL. HEAD (THICKNESS 1.25)	1	
*13	4H.009.11.0.00	JOINT FOR ROCKER COVER	1	
*14	4H.022.11.0.00	JOINT FOR WATER OUTLET MANIFOLD	1	
*15	4H.027.11.0.00	JOINT FOR OIL FILLING BODY	1	
*16	4H.030.11.0.00	JOINT FOR AIR INLET MANIFOLD	1	
*17	4H.035.06.0.00	GASKET (FOR EXHAUST MANIFOLD)	4	
*18	4H.052.11.0.00	JOINT FOR BEARING HOUSING (282.5 CRS)	1	
*19	4H.052.12.0.00	JOINT FOR DELIVERY VOLUTE	1	
*20	4H.053.11.0.00	JOINT FOR THERMOSTAT HOUSING	1	
*21	4H.053.12.0.00	JOINT FOR THERMOSTAT COVER	1	
*22	4H.132.27.0.00	JOINT FOR ADAPTOR (TURBO SIDE)	1	
*23	4H.132.28.0.00	JOINT FOR ADAPTOR (CRANKCASE SIDE)	1	

**TITLE: -SET OF JOINTS, WASHERS,
'O' RINGS & HOSES (4H.2549)**

GROUP: -

SR.NO.	PART NO.	DESCRIPTION	QTY.	REMARKS
*24	4H.132.29.0.00	JOINT FOR LUB OIL DRAIN PIPE	1	
*25	4H.132.31.0.00	JOINT FOR ADAPTOR CRANKCASE SIDE	1	
*26	4H.161.11.0.00	JOINT FOR BREATHER PIPE	1	
*27	4H.223.11.0.00	JOINT FOR AIR INLET PIPE	2	
*28	4H.224.08.0.00	JOINT (AIR PIPE)	1	
*29	4H.522.03.0.00	JOINT FOR EXH. DIFFUSER	2	
*30	6H.029.01.0.00	GASKET (FOR TURBOCHARGER)	1	
*31	4H.842.77.0.00	SET OF WASHERS	1	CONSISTING OF SR. NO.- 32 TO 42
*32	4H.010.93.0.00	MICO COPPER WASHER FOR LEAK OFF PIPE (MICO NO. 2 916 710 603)	8	
*33	50.508.07.000	COPPER WASHER (10X14)	4	
*34	50.508.15.000	COPPER WASHER (17X23)	1	
*35	50.508.16.000	COPPER WASHER (18X22)	2	
*36	50.508.17.000.	COPPER WASHER (18X24)	2	
*37	50.508.18.000	COPPER WASHER (20X24)	1	
*38	50.508.27.000	COPPER WASHER (24X29)	1	

**TITLE: -SET OF JOINTS, WASHERS,
'O' RINGS & HOSES (4H.2549)**

GROUP: -

SR.NO.	PART NO.	DESCRIPTION	QTY.	REMARKS
*39	50.508.29.000	COPPER WASHER (26X32)	3	
*40	50.565.10.000	INTERNAL RUBBER LIP SEALING WASHER -M10- FOR FUEL LINES	2	
*41	50.565.12.000	INTERNAL RUBBER LIP SEALING WASHER -M12- FOR FUEL LINES	5	
*42	50.565.14.000	INTERNAL RUBBER LIP SEALING WASHER -M14- FOR FUEL LINES	13	
*43	4H.619.69.0.00	SET OF 'O' RINGS	1	CONSISTING OF SR. NO.- 44 TO 49
*44	03.010.11.0.00	O RING - L.O.PUMP (1.57X65, 21508)	1	
*45	03.036.01.0.00	O RING - DIPSTICK (2X5, 21515 OR 21511)	3	
*46	2H.008.07.0.00	O RING (FOR CYL.LINER)	3	
*47	2H.014.02.0.00	O RING (FOR DELIVERY TUBE)	2	
*48	3H.009.11.0.00	O RING FOR NOZZLE	1	
*49	3H.132.03.0.00	SEALING RING (FUEL FILTER)	2	

**TITLE: -SET OF JOINTS, WASHERS,
'O' RINGS & HOSES (4H.2549)**

GROUP: -

SR.NO.	PART NO.	DESCRIPTION	QTY.	REMARKS
*50	4H.872.78.0.00	SET OF HOSES	1	CONSISTING OF SR. NO.- 51 TO 60
*51	02.601.04.0.00	HOSE FOR INLET PIPE	1	
*52	4H.006.01.0.00	L.O.SUPPLY HOSE (FIP)	1	
*53	4H.023.02.0.00	BYPASS HOSE	1	
*54	4H.073.01.0.00	HOSE THERMOSTAT TO RADIATOR (45X45X110L)	2	
*55	4H.073.02.0.00	HOSE WATER PUMP TO RADIATOR (45X45X80L)	1	
*56	4H.168.03.0.00	RUBBER HOSE (COMPRESSOR OUTLET)-K24 TURBO	1	
*57	4H.225.12.0.00	HOSE (MAKE UP WATER LINE)	1	
*58	4H.227.02.0.00	HOSE FOR AIR CLEANER (TA ENGINE)	1	
*59	4H.366.07.0.00	HOSE (FOR TURBO DRAIN PIPE)	1	
*60	F6.680.06.0.00	RUBBER HOSE 100 X 100 X 160 LENGTH WITH 4 STEEL RINGS	2	